

Condair Vita Nebulizers

ERSATZTEILE / SPARE PARTS / PIECES DE RECHANGE

Änderungen vorbehalten! / Subject to change! / Modifications réservées!

Vernebler Vita Sky S / Nebulizer Vita Sky S / Nébuliseur Vita Sky S

Pos.	Artikel Article Article	Zusatz Completion Complément	Sky S		Art. Nr. Art. No. Art. No.
			0.9 l/h	1.5 l/h	
101	Sprühkopfgehäuse S Spray head housing S Boîtier tête de vaporisation S		1	1	2615805
102	Abdeckung Sprühkopf S Cover spray head S Couvercle de tête de vaporisation S		1	1	2615806
103	Tülle Sprühkopf Grommet spray head Douille tête de vaporisation		1	1	2615807
104	Achsalventilator 40x40x20 Axial fan 40x40x20 Ventilateur axial 40x40x20		1	1	2615808
105	2/2-Wege Magnetventil DN0.3 HP 24 V 2/2-way solenoid valve DN0.3 HP 24 V Électrovanne 2/2 voies DN0.3 HP 24 V		1	1	2615809
106	Vorfilter Ventil G1/8" x 1/8" AG Valve prefilter G1/8" x 1/8" AG Préfiltre de vanne G1/8" x 1/8" AG		1	1	2615810
107	Düsendichtung VA 1/8" (4 Stk.) Nozzle sealing VA 1/8" (4 pcs) Joint de buse VA 1/8" (4 pcs)		2	2	2615889
108	Düse Nozzle Buse	Diva S	1		2615812
		Diva M		1	2615813
109	Netzanschlussbuchse 24V 2.1x5.5 gerade Power supply socket 24V 2.1x5.5 straight Prise d'alimentation 24 V 2.1 x 5.5 droite		1	1	2615814
110	Sprühkopfkabel 24 VDC Spray head cable 24 VDC Câble de tête de vaporisation 24 V CC		1	1	2606199
111	Hochdruckschlauch-Sprühkopf High pressure hose spray head Tuyau haute pression pour tête de vaporisation		1	1	2615816

Vernebler Vita Sky M1 / Nebulizer Vita Sky M1 / Nébuliseur Vita Sky M1

Pos.	Artikel Article Article	Zusatz Completion Complément	Sky M1			Art. Nr. Art. No. Art. No.
			2.5 l/h Ring	1.5 l/h String	2.5 l/h String	
201	Sprühkopfgehäuse M Spray head housing M Boîtier tête de vaporisation M		1	1	1	2615819
202	Abdeckung Einzel-Sprühkopf M - Ringleitung Cover single spray head M - ring line Couvercle de tête de vaporisation simple M - ligne en anneau		1			2615820
203	Abdeckung Einzel-Sprühkopf mittel - Stichleitung Cover single spray head medium - stringline Couvercle de tête de vaporisation simple moyen - ligne de branchement			1	1	2615821
204	Tülle Sprühkopf Grommet spray head Douille tête de vaporisation		1	1	1	2615807
205	Achsalventilator 60x60x25 24 V Axial fan 60x60x25 24 V Ventilateur axial 60x60x25 24 V		1	1	1	2615822
206	2/2-Wege Magnetventil DN0.3 HP 24 V 2/2-way solenoid valve DN0.3 HP 24 V Électrovanne 2/2 voies DN0.3 HP 24 V		1			2615809
207	Vorfilter Ventil G1/8" x 1/8" AG Valve prefilter G1/8" x 1/8" AG Préfiltre de vanne G1/8" x 1/8" AG		1			2615810
208	Düsendichtung VA 1/8" (4 Stk.) Nozzle sealing VA 1/8" (4 pcs) Joint de buse VA 1/8" (4 pcs)		3			2615889
209	Düse Diva L Nozzle Diva L Buse Diva L		1			2615823
210	Düse Nozzle Buse	Multitech 1.5		1		2615824
		Multitech 2.5			1	2615825
211	Düsenadapter - Ringleitung Nozzle adapter - ring line Adaptateur de buse - ligne en anneau		1			2615826
212	Düsenadapter - Stichleitung Nozzle adapter - stringline Adaptateur de buse - ligne de branchement			1	1	2615827
213	Düsenabstandshalter Edelstahl (16 mm) Nozzle spacer stainless steel (16 mm) Entretoise de buse en acier inoxydable (16 mm)			1		2615828
214	Netzanschlussbuchse 24V 2.1x5.5 gerade Power supply socket 24V 2.1x5.5 straight Prise d'alimentation 24 V 2.1 x 5.5 droite		1	1	1	2615814
215	Sprühkopfkabel 24 VDC Spray head cable 24 VDC Câble de tête de vaporisation 24 V CC		1	1	1	2606199
216	Hochdruckschlauch-Sprühkopf High pressure hose spray head Tuyau haute pression pour tête de vaporisation		1	1	1	2615816

Vernebler Vita Sky M2 / Nebulizer Vita Sky M2 / Nébuliseur Vita Sky M2

Pos.	Artikel Article Article	Zusatz Completion Complément	Sky M2			Art. Nr. Art. No. Art. No.
			5 l/h Ring	3 l/h String	5 l/h String	
301	Sprühkopfgehäuse M Spray head housing M Boîtier tête de vaporisation M		1	1	1	2615819
302	Abdeckung Doppel-Sprühkopf M - Ringleitung Cover double spray head M - ring line Couvercle de tête de vaporisation double M - ligne en anneau		1			2615829
303	Abdeckung Doppel-Sprühkopf mittel - Stichleitung Cover double spray head medium - stringline Couvercle de tête de vaporisation double moyen - ligne de branchement			1	1	2615830
304	Tülle Sprühkopf Grommet spray head Douille tête de vaporisation		1	1	1	2615807
305	Achsalventilator 60x60x25 24 V Axial fan 60x60x25 24 V Ventilateur axial 60x60x25 24 V		1	1	1	2615822
306	2/2-Wege Magnetventil DN0.3 HP 24 V 2/2-way solenoid valve DN0.3 HP 24 V Électrovanne 2/2 voies DN0.3 HP 24 V		1			2615809
307	Vorfilter Ventil G1/8" x 1/8" AG Valve prefilter G1/8" x 1/8" AG Préfiltre de vanne G1/8" x 1/8" AG		1			2615810
308	Düsendichtung VA 1/8" (4 Stk.) Nozzle sealing VA 1/8" (4 pcs) Joint de buse VA 1/8" (4 pcs)		3			2615889
309	Düse Diva L Nozzle Diva L Buse Diva L		2			2615823
310	Düse Nozzle Buse	Multitech 1.5		2		2615824
		Multitech 2.5			2	2615825
311	Y-Verteiler Sprühkopf M Y distributor spray head M Distributeur en Y tête de vaporisation M		1			2615831
312	Doppelnippel V4A 1/8" Double nipple V4A 1/8" Raccord double V4A 1/8"		1			2615833
313	Y-Düsenadapter Nozzle Y-adapter Adaptateur de buse en Y			1	1	2615832
314	Düsenabstandshalter Edelstahl (16 mm) Nozzle spacer stainless steel (16 mm) Entretoise de buse en acier inoxydable (16 mm)			1		2615828
315	Netzanschlussbuchse 24V 2.1x5.5 gerade Power supply socket 24V 2.1x5.5 straight Prise d'alimentation 24 V 2.1 x 5.5 droite		1	1	1	2615814
316	Sprühkopfkabel 24 VDC Spray head cable 24 VDC Câble de tête de vaporisation 24 V CC		1	1	1	2606199
317	Hochdruckschlauch-Sprühkopf High pressure hose spray head Tuyau haute pression pour tête de vaporisation		1	1	1	2615816

Verteilblock Vita Sky T1/T2 / Manifold Block Vita Sky T1/T2 / Bloc distribution Vita Sky T1/T2

Pos.	Artikel Article Article	Zusatz Completion Complément	T1/T2	Art. Nr. Art. No. Art. No.
401	Baugruppe Wandhalterung Wall bracket assembly Ensemble du support mural		1	2607881
402	2-Wege-DC-Hohlstecker-Splitter, 2.1 mm 2-Way 2.1 mm DC barrel jack splitter Répartiteur d'alimentation prise creux CC 2 voies, 2.1 mm		1	2615835
403	Messanschluss M16x2 einteilig Measuring connection M16x2 one-piece Raccord de mesure M16x2 monobloc		2	2615836
404	Gerade-Einschraubverbinder 6L / G1/4" Straight screw-in fitting 6L / G1/4" Raccord à visser droit 6L / G1/4"		1	2615887
405	Tülle PVC Grommet PVC Douille PVC		3	2615837
406	Verteilblock Sky T Manifold block Sky T Bloc de distribution Sky T		1	2615838

Vernebler Vita Stream / Nebulizer Vita Stream / Nébuliseur Vita Stream

Pos.	Artikel Article Article	Zusatz Completion Complément	Vita Stream				Art. Nr. Art. No. Art. No.
			20 l/h Ring	36 l/h Ring	20 l/h String	36 l/h String	
501	Ventilator ø133 Fan ø133 Ventilateur ø133	115 V	1	1	1	1	2615858
		230V	1				2615859
502	Düse Diva L Nozzle Diva L Buse Diva L		8		8		2615823
503	Düse Nozzle Buse	Multitech 2.5	8		8		2615825
		Multitech 4.5		8		8	2615860
504	Swivel Adapter für Multitech-Düse, Edelstahl Swivel adapter for Multitech nozzle, stainless steel Adaptateur pivotant pour buse Multitech, acier inoxydable		x	x	x	x	2614890
505	Verlängerungsstück für Düsen Expansion piece for nozzels Pièce d'extension pour buses		x	x	x	x	2616004
506	Blinddüse Blind nozzle Pièce d'extension pour buses		x	x	x	x	2614885
507	Düsendichtung VA 1/8" (4 Stk.) Nozzle sealing VA 1/8" (4 pcs) Joint de buse VA 1/8" (4 pcs)		8		8		2615889
508	Adapter für Düse Diva Adapter for diva nozzle Adaptateur pour buse Diva		8		8		2615890
509	O-Ring 6x1 (4 Stk.) O-ring 6x1 (4 pcs) Joint torique 6x1 (4 pcs)		x	x	x	x	2616005
510	2/2-Wege Magnetventil NC 1/4" 2/2-way solenoid valve NC 1/4" Électrovanne 2/2 voies NC 1/4"	115 V	1	1			2615863
		230V	1	1			2615864
511	Druckring quadratisch Pressure ring square Anneau de pression carré		1	1	1	1	2615865
512	Anschlussschlauch 174 mm Connecting hose 174 mm Tuyau de raccordement 174 mm		1	1	1	1	2615866
513	Hochdruckschlauch DN4 High pressure hose DN4 Tuyau haute pression DN4		1	1	1	1	2615867
514	Kondensator 5 uF, 470 VAC Capacitor 2 uF, 470 VAC Condensateur 2 uF, 470 VAC	115 V	1	1	1	1	2615868
		230V	1	1	1	1	2615869
515	Versorgungskabel - 287 mm Supply cable - 287 mm Câble d'alimentation - 287 mm		1	1	1	1	2615870
516	Ventilsteckerkabel - 300 mm Valve Plug Cable - 300 mm Câble de prise de vanne - 300 mm		1	1	1	1	2615871
517	Kondensatorkabel - 300 mm Capacitor Cable - 300 mm Câble de condensateur - 300 mm		1	1	1	1	2615872
518	Anschlussklemme 4-polig Terminal Clamp 4 poles Borne de raccordement 4 pôles		1	1	1	1	2615873
519	Klammersockel D8 Socket Clamp D8 Socle d'attache D8		8	8	8	8	2615874

Pos.	Artikel Article Article	Zusatz Completion Complément	Vita Stream				Art. Nr. Art. No. Art. No.
			20 l/h Ring	36 l/h Ring	20 l/h String	36 l/h String	
520	Filter 20 µm Filter 20 µm Filtre 20 µm		1	1	1	1	2615902
521	Filter 20 µm kpl. Filter 20 µm cpl. Filtre 20 µm cpl.		1	1	1	1	2615903
522	Winkelschraubung 6L-G1/8" Elbow fitting 6L-G1/8" Raccord coudé 6L-G1/8"		1	1	1	1	2615906

Vernebler Vita Line / Nebulizer Vita Line / Nébuliseur Vita Line

Pos.	Artikel Article Article	Zusatz Completion Complément	Line	Art. Nr. Art. No. Art. No.
601	Düse Nozzle Buse	Multitech 1.5	x	2615824
		Multitech 2.5	x	2615825
		Multitech 4.5	x	2615860
		Multitech 6.5	x	2615875
602	Düsen-Schwenkadapter für Multitech-Düse, Edelstahl Nozzle swivel adapter for Multitech nozzle, stainless steel Adaptateur pivotant pour buse Multitech, acier inoxydable		x	2614890
603	Blinddüse Blind nozzle Pièce d'extension pour buses		x	2614885
604	T-Stück für 2 Düsen mit Schlauchanschluss T-piece for 2 nozzles with hose connection Raccord en T pour 2 buses avec raccord de tuyau		x	2614988
605	T-Stück für 2 Düsen T-piece for 2 nozzles Raccord en T pour 2 buses		x	2614481
606	T-Stück für 1 nozzle T-piece for 1 nozzle Raccord en T pour 1 buse		x	2613149
607	Endstück für 2 Düsen End piece for 2 nozzles Embout pour 2 buses		x	2613116
608	Rohrverbindungsstück Pipe connection piece Pièce de raccordement de tube		x	2613147
609	Schlauchanschlusstück Hose connection piece Pièce de raccordement de tuyau		x	2613148
610	Standardrohr Standard pipe Tube standard	0.25 m	x	2613306
		0.5 m	x	2613307
		0.75 m	x	2613308
		1.0 m	x	2613309
		2.0 m	x	2613310
611	O-Ring zu Standardrohr O-ring to standard pipe Joint torique pour tube standard		x	2615052
612	Wandaufhängung für System kpl. Wall suspension for system cpl. Suspension murale pour système cpl.		x	2615056
613	Deckenaufhängung für System kpl. Ceiling suspension for system cpl. Suspension de plafond pour système cpl.		x	2615057

Halterungen Vita Sky Vernebler / Supports Vita Sky nebulizers / Supports de nébuliseurs Vita Sky

Pos.	Artikel Article Article	Zusatz Completion Complément		Art. Nr. Art. No. Art. No.
701	Wandhalterung für Sprühkopf Spray head wall bracket Support mural pour tête de vaporisation		x	
702	Sprühkopf-Deckenaufhängung Spray head ceiling hanger Support de plafond pour tête de vaporisation		x	2607671
703	Sprühkopf-Deckenaufhängung Premium Spray head ceiling hanger Premium Support de plafond Premium pour tête de vaporisation		x	2607823

Zonenventile / Zone valves / Vannes de zone

Pos.	Artikel Article Article	Zusatz Completion Complément	0 - 76 l	60 - 360 l	120 - 1800 l	Art. Nr. Art. No. Art. No.
800	Spule 24V-DC-18W-IP67 Coil 24V-DC-18W-IP67 Bobine 24V-DC-18W-IP67		1	1	1	2616141
801	Spulenkabel 24V Coil cable 24V Cable de bobine 24V		1	1	1	2616142
802	3/2-Wege Hochdruckventil - kleine Volumenströme 3/2 high pressure valve - small flows Vanne haute pression 3/2 voie - petits débits		1			2616164
803	Armaturset NC Armature kit NC Kit d'armature NF		1	1	1	2616168
804	Armaturset NO Armature kit NO Kit d'armature NO		1	1	1	2616169
805	Blendenset 4 VDHT 2E 1.4 Orifice kit 4 VDHT 2E 1.4 Kit d'orifice 4 VDHT 2E 1.4		1			2616170
806	Kolbensen, VDHT D 18.1 Piston kit, VDHT D 18.1 Kit piston, VDHT D 18.1			1	1	2616171
807	Blendenset 1 VDHT 1.0 Orifice kit 1 VDHT 1.0 Kit d'orifice 1 VDHT 1.0			1	1	2616172
808	Dichtungskit VDHT Sealing kit VDHT Kit d'étanchéité VDHT				1	2616173
809	Hochdruckkugelhahn 10 l High pressure ball valve 10 l Vanne à boisseau sphérique haute pression 10 l		1	1	1	2616143
810	Einschraubfilter G1/4" 80 µm Screw-in filter G1/4" 80 µm Filtre à visser G1/4" 80 µm		1			2613996
811	Filtersiebadapter G1/4" Filter mesh adaptor G1/4" Adaptateur de maille de filtre G1/4"		1			2613995
812	JG Ablauf Adapterset JG drain adapter set Kit adaptateur de vidange JG		1		1	2617007
813	Patronen-Rückschlagventil Cartridge check valve Clapet anti-retour à cartouche		1	1	1	2606525

Pos.	Artikel Article Article	Zusatz Completion Complément	0 - 76 l	60 - 360 l	120 - 1800 l	Art. Nr. Art. No. Art. No.
814	3/2-Wege Hochdruckventil - mittlere Volumenströme 3/2 high pressure valve - medium flows Vanne haute pression 3/2 voie - débits moyens			1		2616165
815	Einschraubverbinder BSP D10-3/8" Screw-in connector BSP D10-3/8" Raccord à visser BSP D10-3/8"			1		2616144
816	Winkelreduzierstück Elbow Reducer Réducteur de coude			1		2616145
817	Boden für Filterhalter Bottom for filter holder Fond pour porte-filtre			1	1	2616146
818	Überwurfmutter KW24x14.5 Union nut KW24x14.5 Écrou-raccord KW24x14.5			1	1	2616147
819	Gehäuse für Filter 3/8" HP Housing for filter 3/8" HP Boîtier pour filtre 3/8" HP			1	1	2616148
820	Filterhalter lang Filter holder long Porte-filtre long			1	1	2616151
821	O-Ring ø13.5 x ø2.5 O-ring ø13.5 x ø2.5 Joint torique ø13.5 x ø2.5			1	1	2615902
822	2/2-Wege Hochdruck NC-Ventil G3/8" 2/2 way high pressure NC valve G3/8" Vanne haute pression NF 2/2 voie G3/8"				1	2616166
823	2/2-Wege Hochdruck NO-Ventil G3/8" 2/2 way high pressure NO valve G3/8" Vanne haute pression NO 2/2 voie G3/8"				1	2616167
824	Spezial Kegelschraubung L12 3-8 Custom cone screw connection L12 3-8 Raccord à vis conique spécial L12 3-8			1	1	2617038
825	Spezial Gerade-Einschraubverbinder L8 3-8 Custom straight screw-in connection L8 3-8 Raccord à vis droit spécial L8 3-8			1		2617039

Condair Vita Sky S

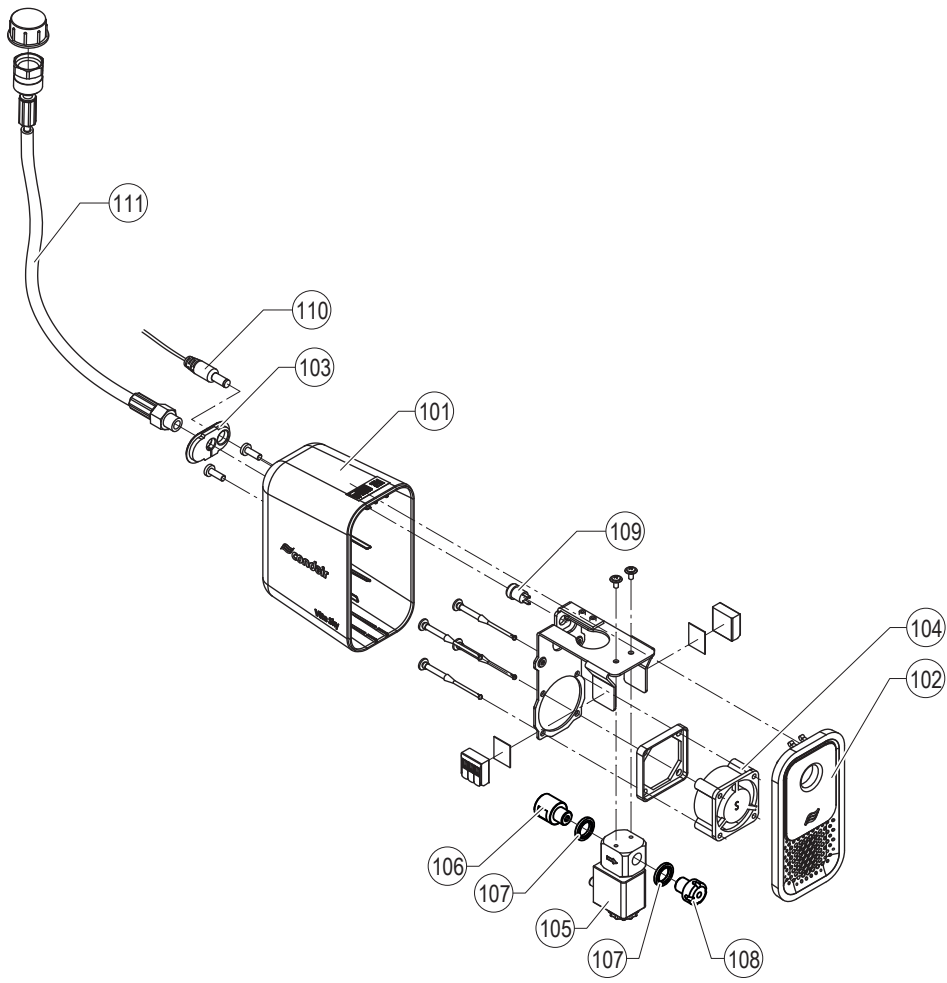

Condair Vita Sky M1 Ringleitung / Condair Vita Sky M1 ringline / Condair Vita Sky M1 conduite circulaire

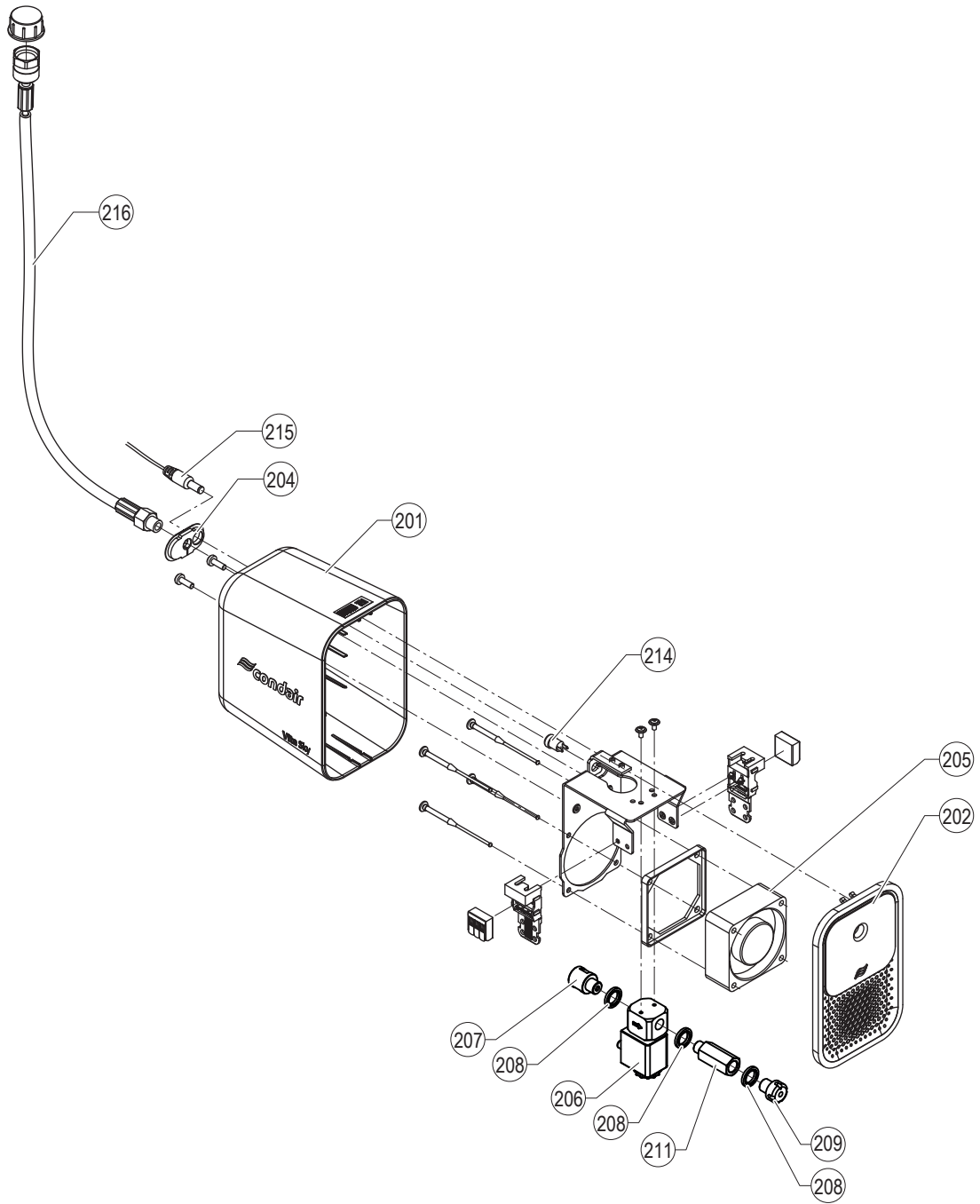

Condair Vita Sky M1 Stichleitung / Condair Vita Sky M1 stringline / Condair Vita Sky M1 conduite de bras

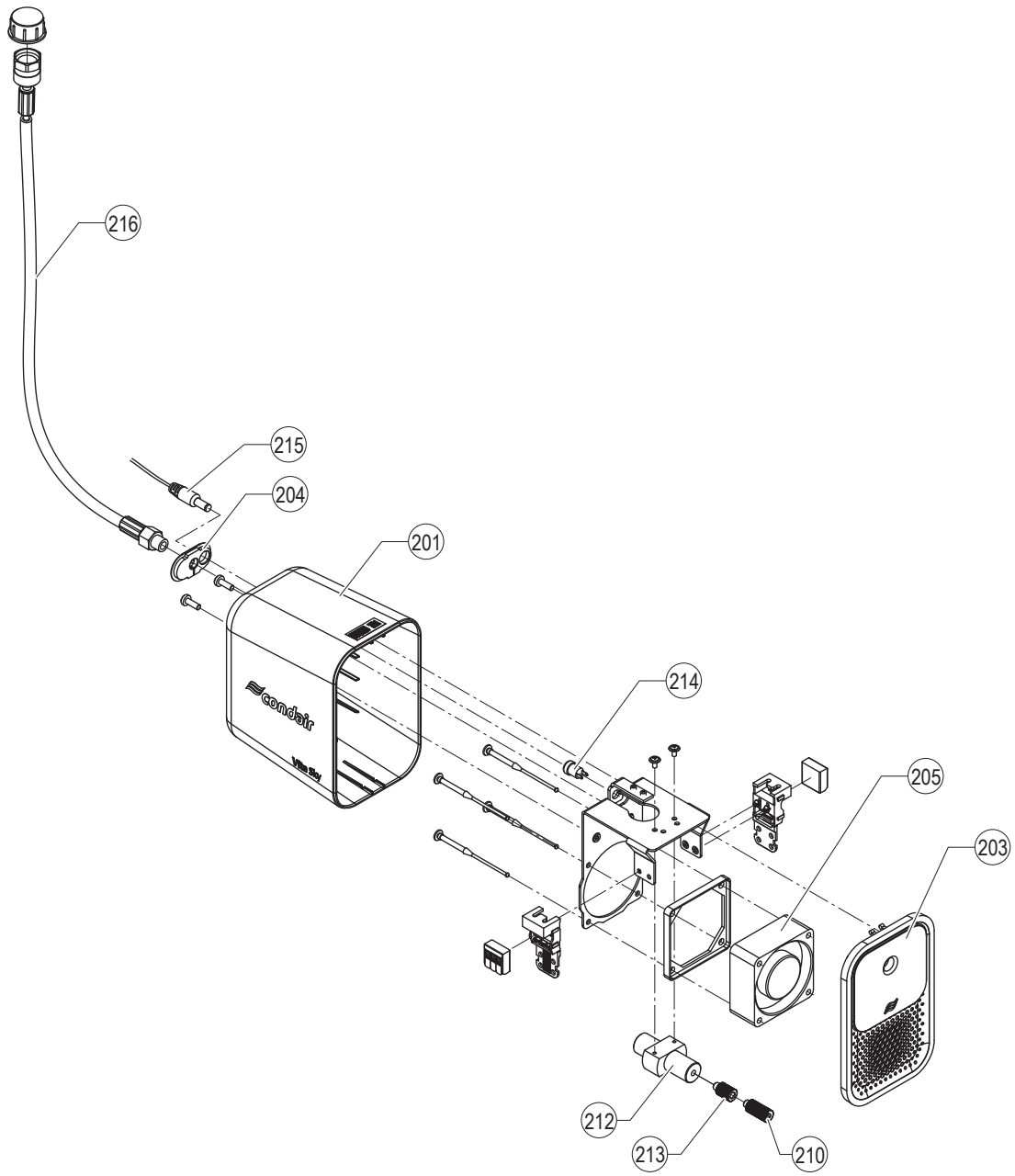

Condair Vita Sky M2 Ringleitung / Condair Vita Sky M2 ringline / Condair Vita Sky M2 conduite circulaire

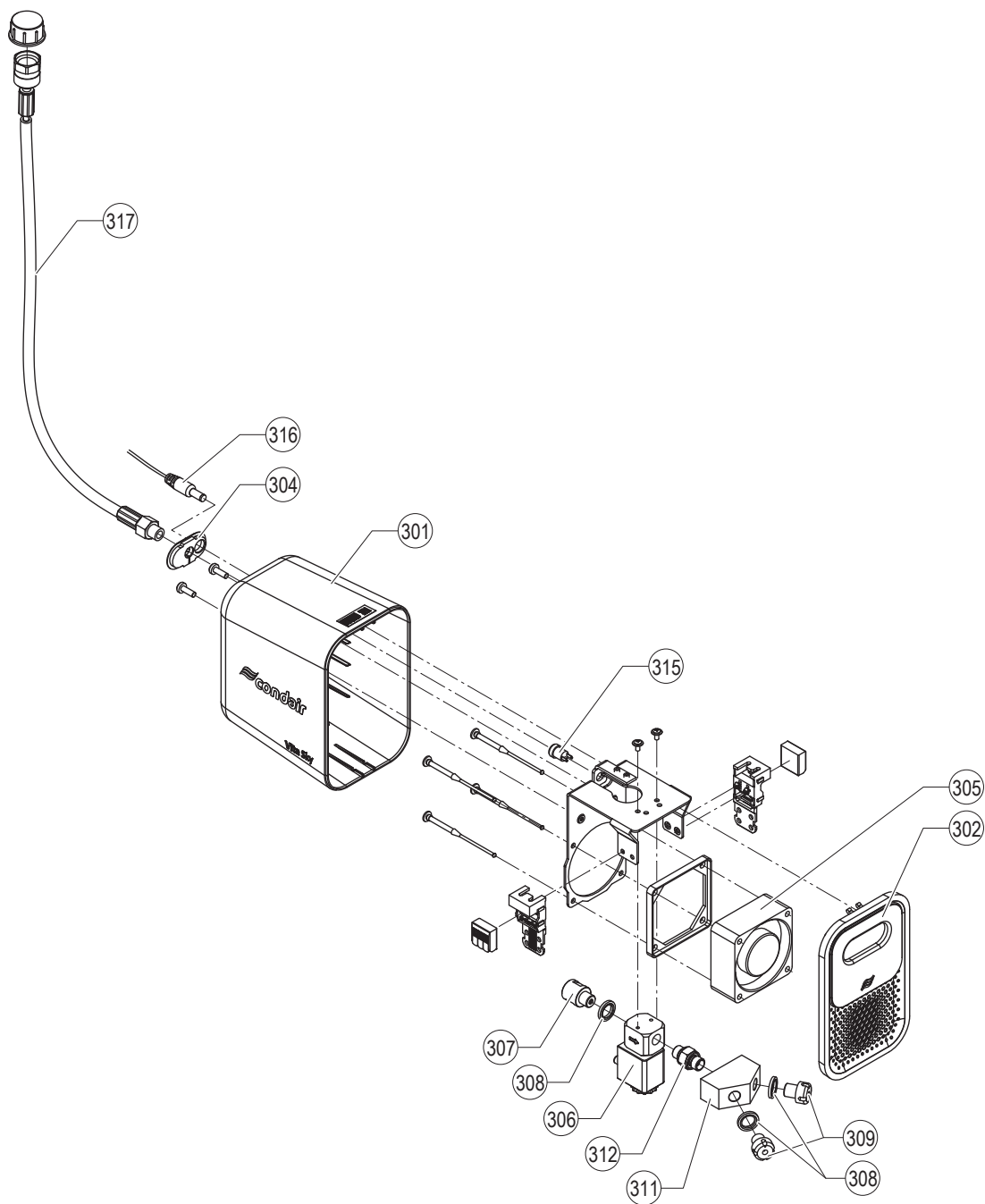

Condair Vita Sky M2 Stichleitung / Condair Vita Sky M2 stringline / Condair Vita Sky M2 conduite de bras

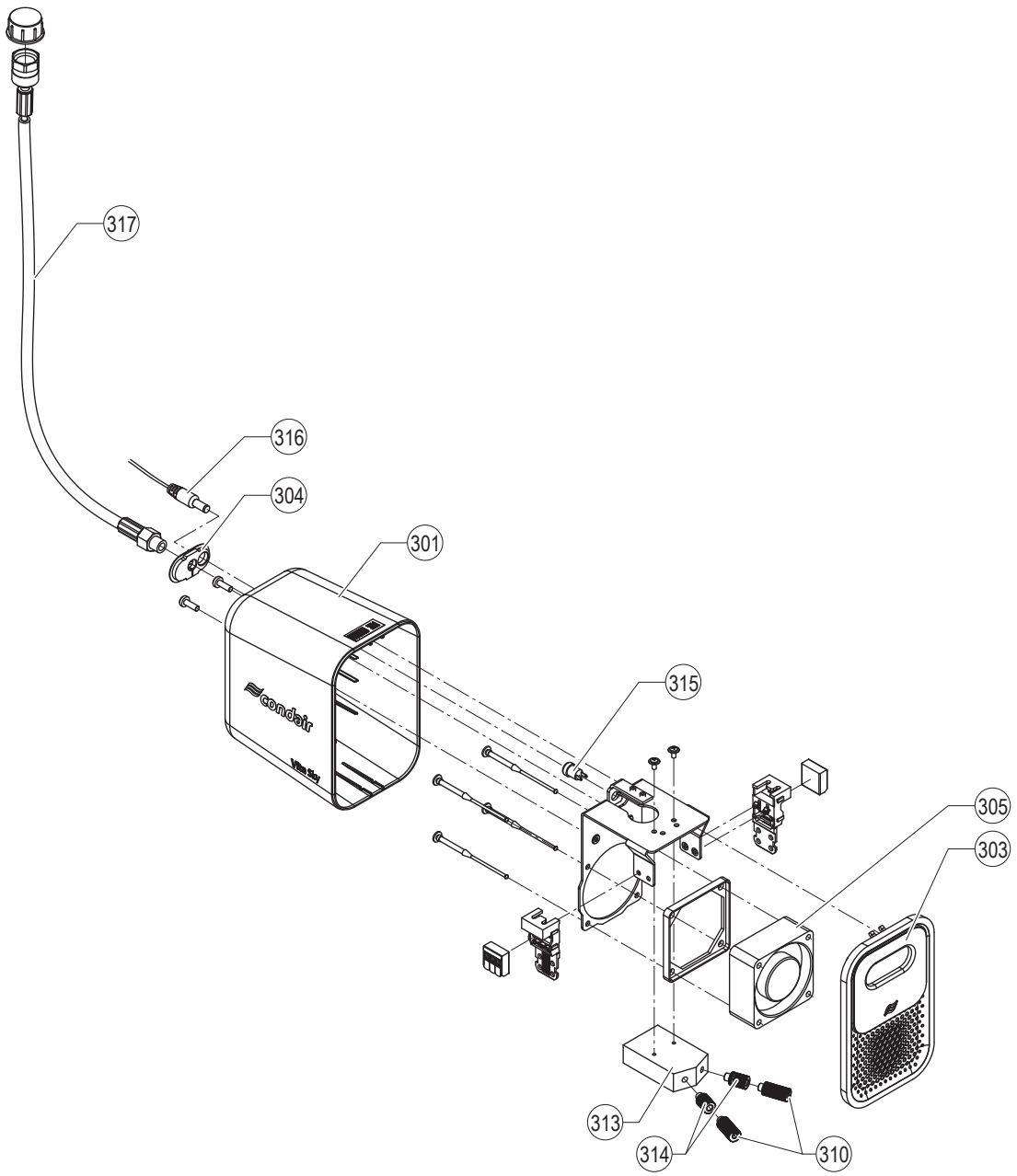

Verteilblock Vita Sky T1/T2 / Manifold block Vita Sky T1/T2 / Bloc distributeur Vita Sky T1/T2

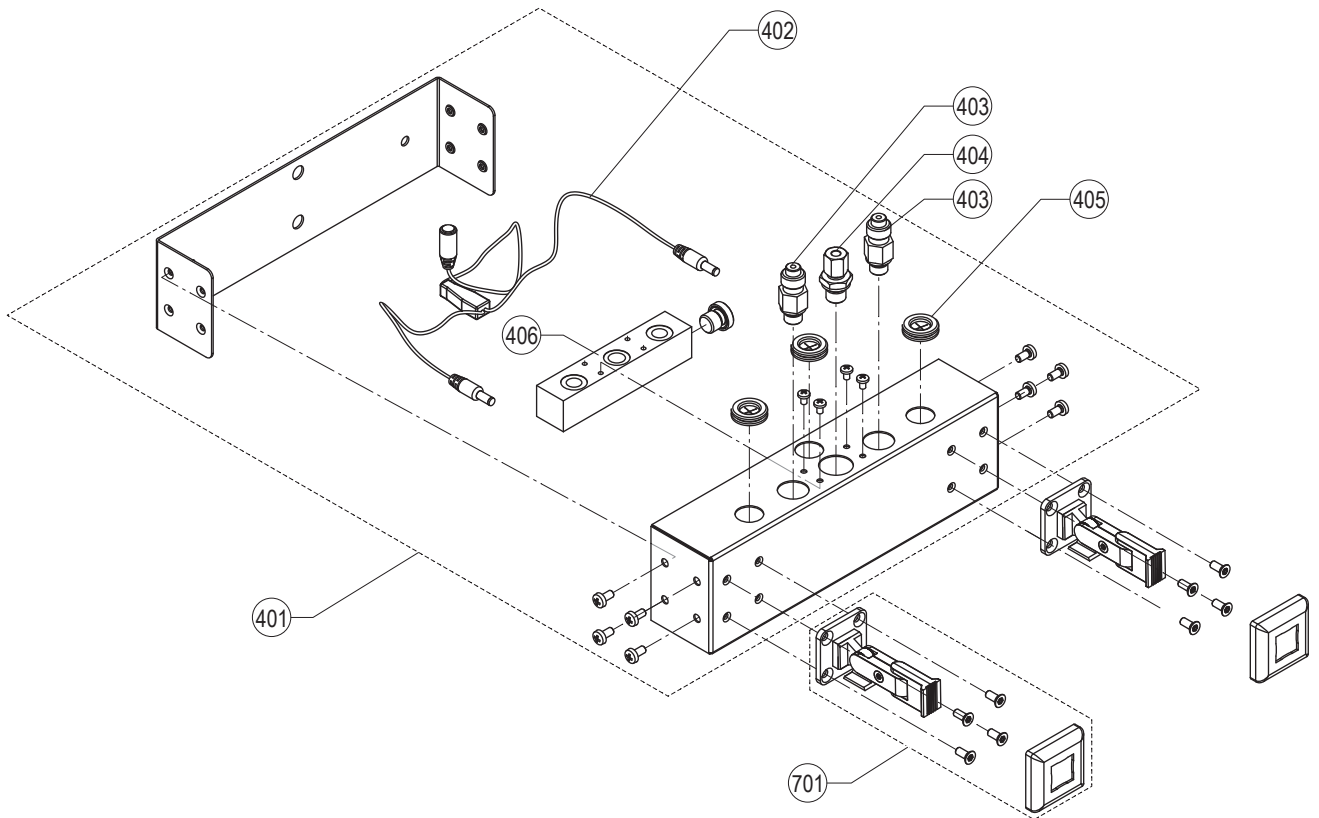

Condair Vita Stream Ringleitung / Condair Vita Stream ringline / Condair Vita Stream conduite circulaire

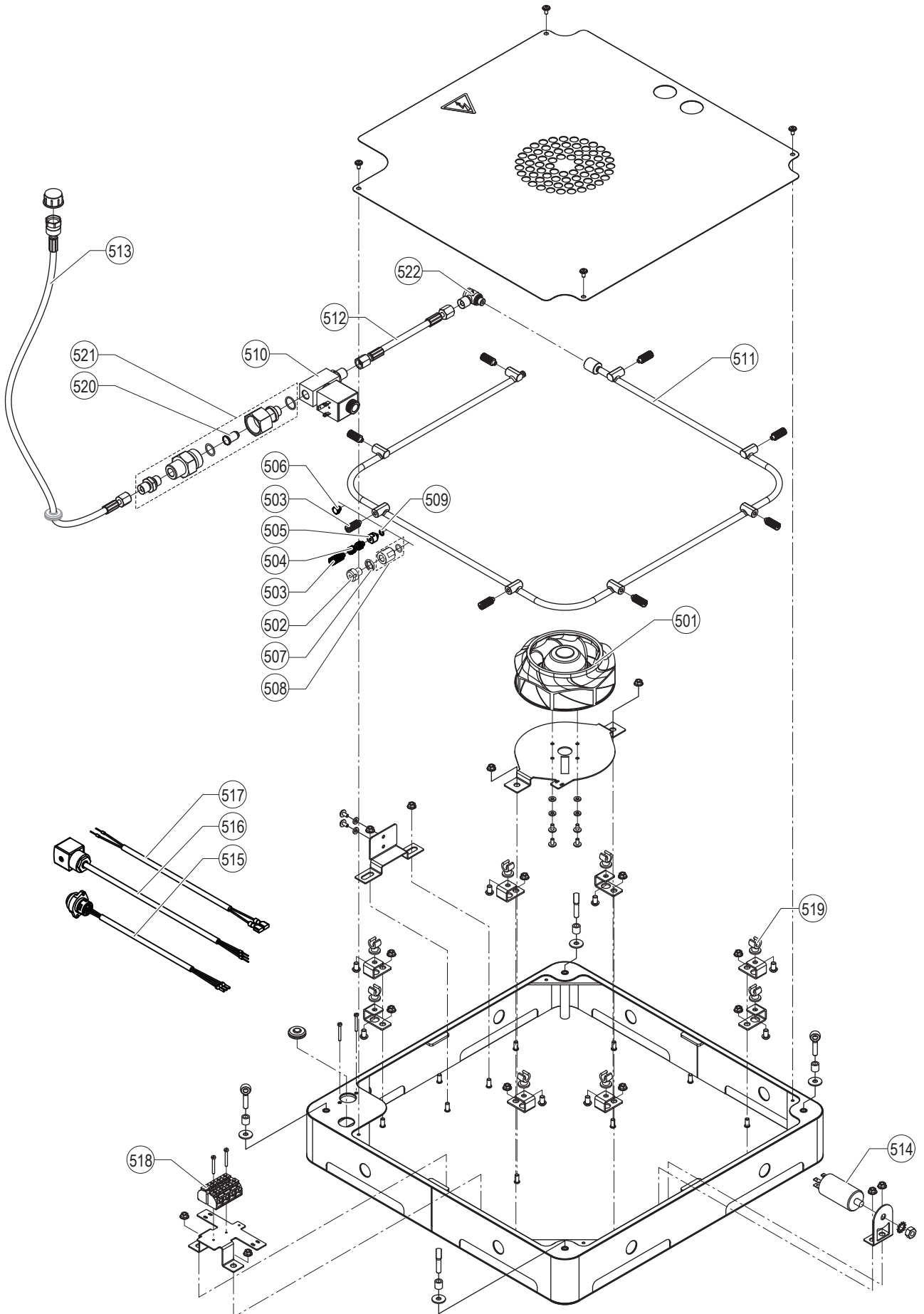

Condair Vita Stream Stichleitung / Condair Vita Stream stringline / Condair Vita Stream conduite de bras

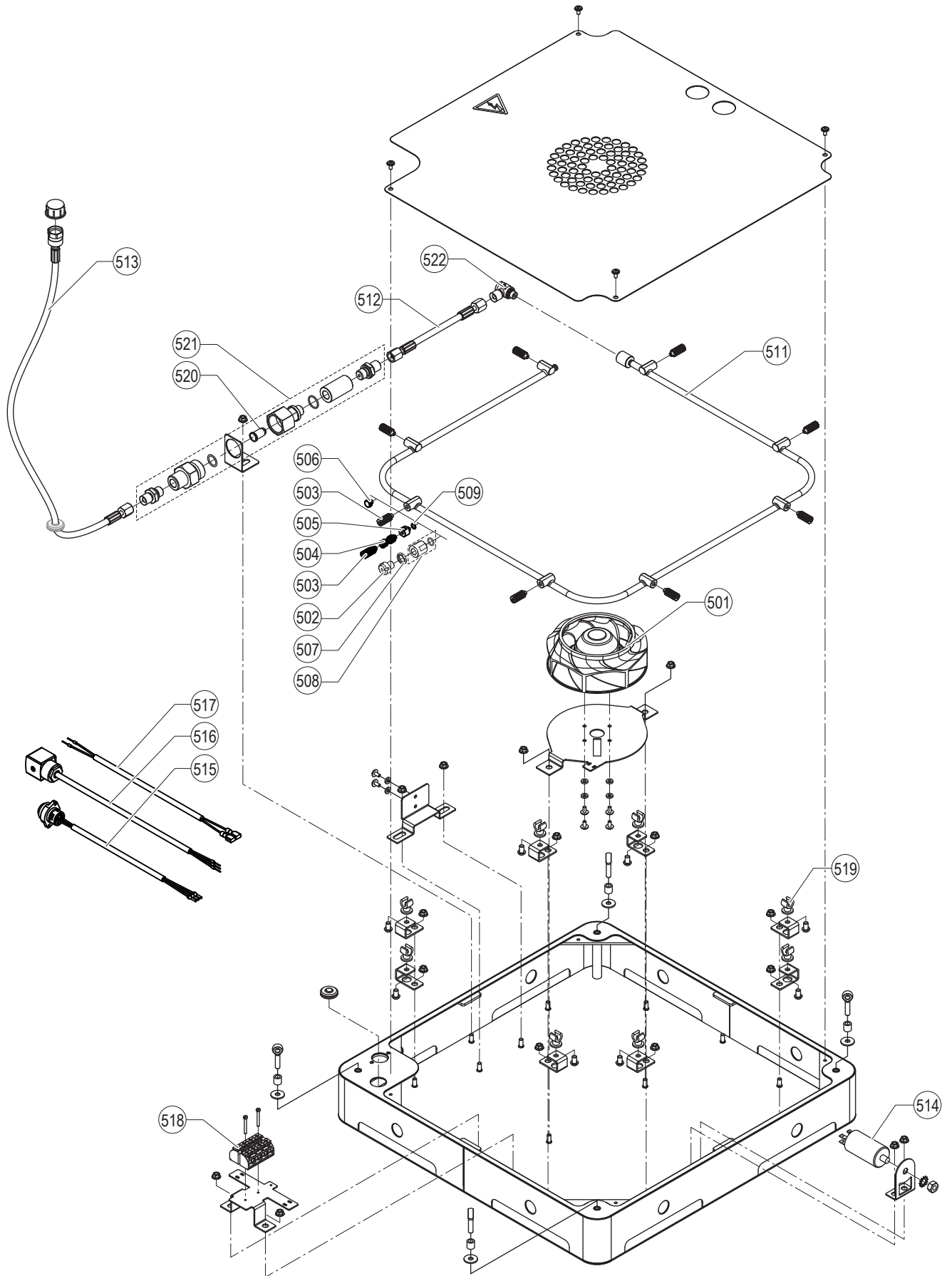

Condair Vita Line

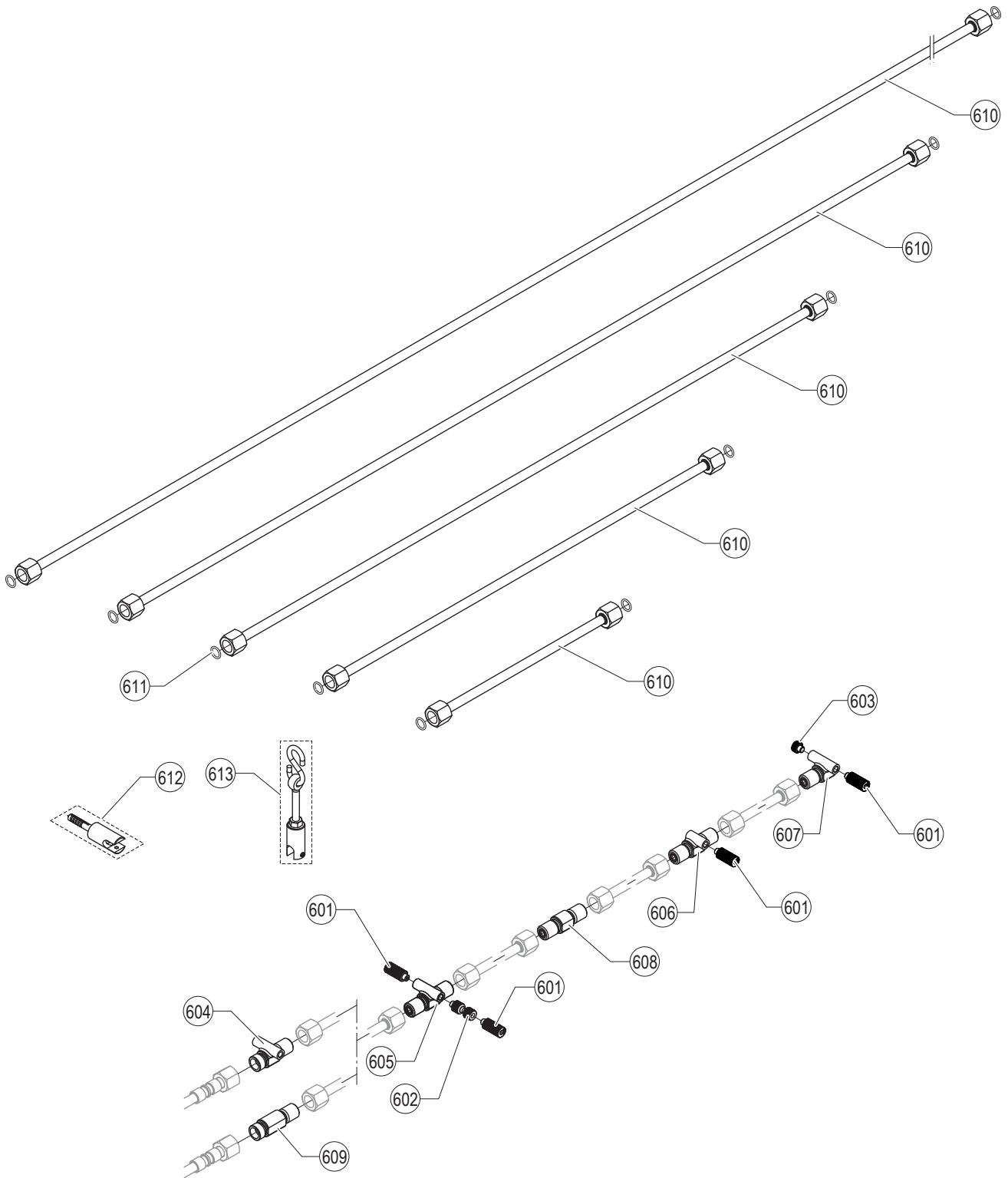

Vita Sky Vernebler-Halter / Vita Sky nebulizer supports / Supports de nébuliseur Vita Sky

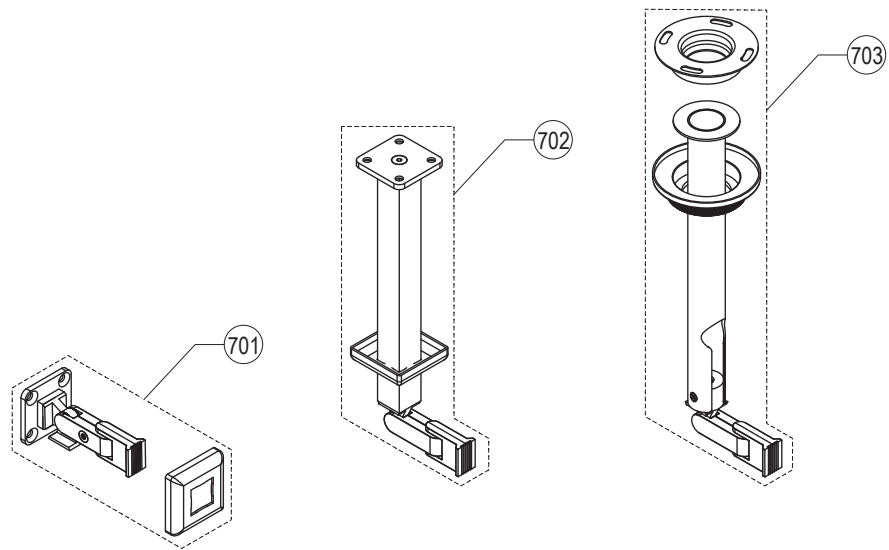

Zonenventil 0 - 76 I / Zone valve 0 - 76 I / Vanne de zone 0 - 76 I

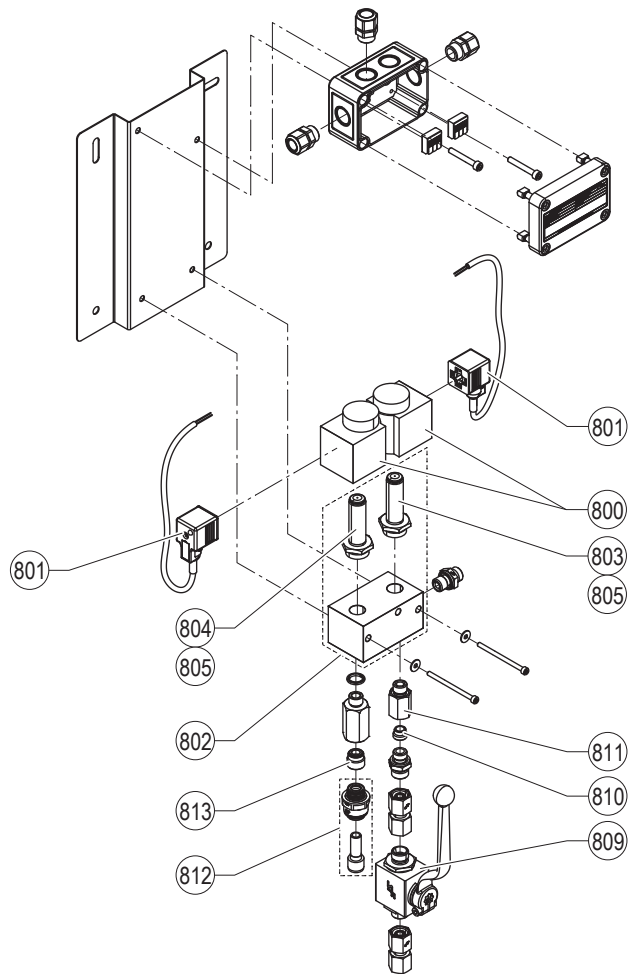

Zonenventil 60 - 360 I / Zone valve 60 - 360 I / Vanne de zone 60 - 360 I

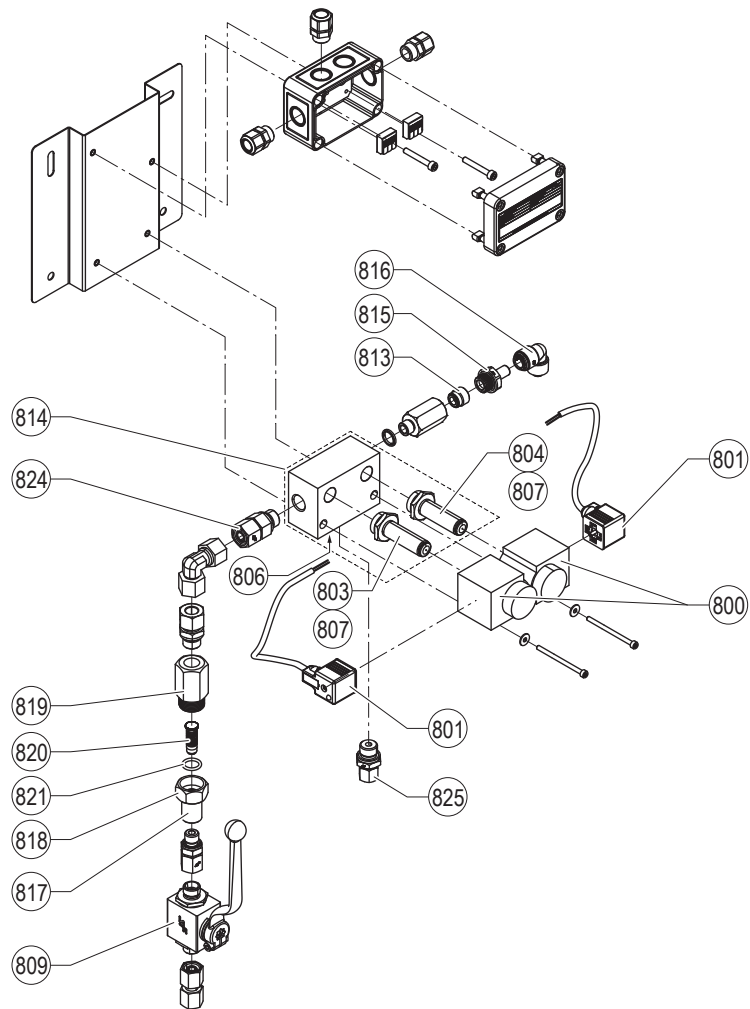

Zonenventil 120 - 1800 l / Zone valve 120 - 1800 l / Vanne de zone 120 - 1800 l

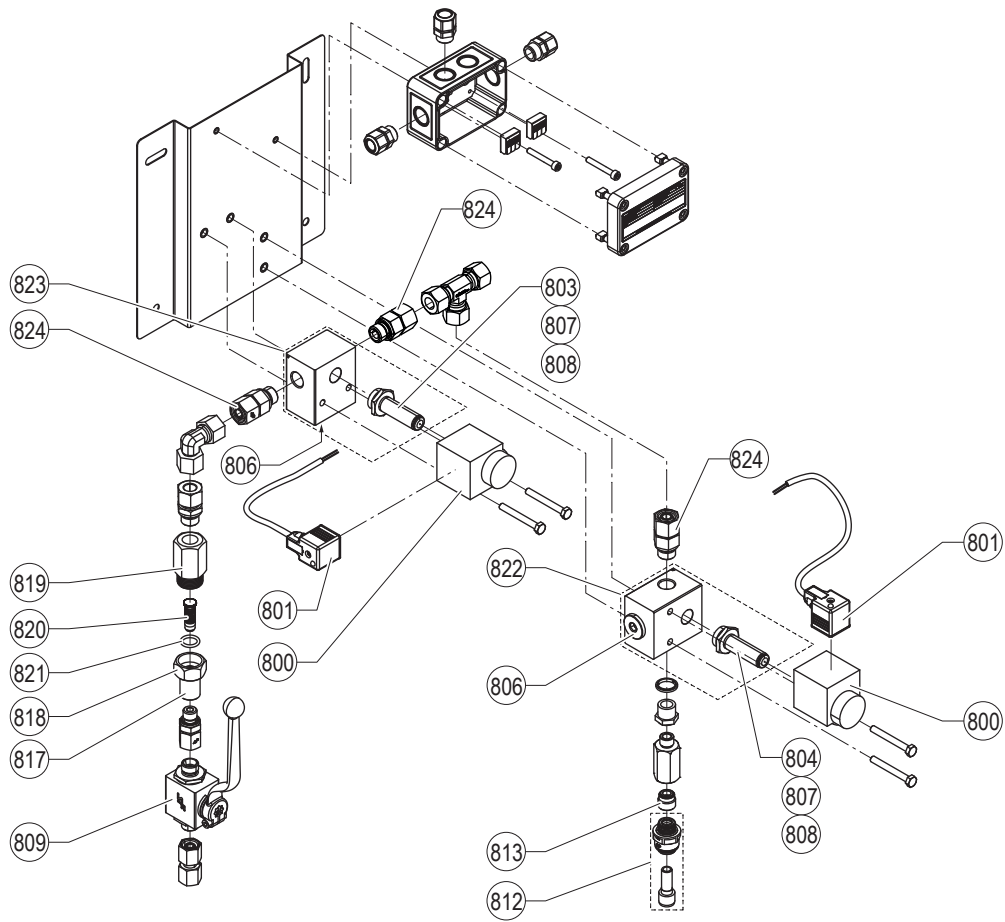

CONSULTING, SALES AND SERVICE:

Condair Group AG
Gwattstrasse 17, 8808 Pfäffikon SZ, Switzerland
Phone: +41 55 416 61 11, Fax +41 55 588 00 07
info@condair.com, www.condairgroup.com

