

**READ AND SAVE THESE INSTRUCTIONS**

# INSTALLATION MANUAL

High pressure water treatment system  
**Condair Vita Power**

# Thank you for choosing Condair

Installation date (MM/DD/YYYY):

Commissioning date (MM/DD/YYYY):

Location ref.:

Model:

Serial number:

## Proprietary Notice

This document and the information disclosed herein are proprietary data of Condair Group AG. Neither this document, nor the information contained herein shall be reproduced, used, or disclosed to others without the written authorization of Condair Group AG, except to the extent required for installation or maintenance of recipient's equipment.

## Liability Notice

Condair Group AG does not accept any liability due to incorrect installation or operation of the equipment or due to the use of parts/components/equipment that are not authorized by Condair Group AG.

## Copyright Notice

© Condair Group AG All rights reserved.

Technical modifications reserved

# Contents

<b>1</b>	<b>Introduction</b>	<b>5</b>
1.1	Preface	5
1.2	Notes on the installation manual	5
<b>2</b>	<b>For your safety</b>	<b>7</b>
<b>3</b>	<b>Product overview</b>	<b>10</b>
3.1	Model overview	10
3.2	Product designation	10
3.3	System overview Condair Vita Power RO-DI-CO-UV-HP	11
3.4	System overview Condair Vita Power RO-UV-HP	12
3.5	System overview Condair Vita Power UV-HP	13
3.6	System overview Condair Vita Power RO	14
3.7	Options	15
3.8	Accessories	16
<b>4</b>	<b>Receiving and storage</b>	<b>17</b>
4.1	Inspection	17
4.2	Storage and Transportation	17
<b>5</b>	<b>Installation</b>	<b>18</b>
5.1	Safety notes on mounting and installation work	18
5.2	Installation room requirements	19
5.3	Positioning and mounting instructions	20
5.4	System dimensions	21
5.4.1	System dimensions Vita Power RO-DI-CO-UV-HP	21
5.4.2	System dimensions Vita Power RO-UV-HP	22
5.4.3	System dimensions Vita Power UV-HP	23
5.4.4	System dimensions Vita Power RO	24
5.5	Mounting of the components of the Condair Vita Power	25
5.5.1	Mounting of Condair Vita Power	25
5.5.2	Positioning and mounting of the water softener	26
5.5.3	Positioning of the deionizing cartridges	26
5.5.4	Positioning of the CO <sub>2</sub> compressed gas cylinder	26
5.6	Water installation	26
5.6.1	Important notes on water installation	26
5.6.2	Water supply connection	27
5.6.3	Connecting the optional water softener to the Condair Vita Power	30
5.6.4	Connecting the deionizing cartridges to the Condair Vita Power	31
5.6.5	Connecting the drain line to the Condair Vita Power	32
5.6.6	Connecting the high pressure lines to the Condair Vita Power	33
5.7	Connecting the CO <sub>2</sub> compressed gas cylinder	34
5.8	Electrical installation	36
5.8.1	Notes on electrical installation	36
5.8.2	Wiring diagram Condair Vita Power	37
5.8.3	Electrical installation work	38
5.8.3.1	Electrical installation of additional components	38
5.8.3.2	Connecting the 400 VAC power supply	39
5.8.3.3	Connecting the CAN bus cable of the area control	40

<b>6</b>	<b>Technical data</b>	<b>41</b>
<b>7</b>	<b>Appendix</b>	<b>42</b>
7.1	Hydraulic diagrams	42
7.1.1	Hydraulic diagram Condair Vita Power RO-DI-CO-UV-HP	42
7.1.2	Hydraulic diagram Condair Vita Power RO-UV-HP	46
7.1.3	Hydraulic diagram Condair Vita Power UV-HP	49
7.1.4	Hydraulic diagram Condair Vita Power RO	50

# 1 Introduction

---

## 1.1 Preface

We thank you for having purchased the **Condair Vita Power high pressure water treatment system** (also named Condair Vita Power for short).

The Condair Vita Power incorporates the latest technical advances and meets all recognized safety standards. Nevertheless, improper use of the Condair Vita Power may result in danger to the user or third parties and/or damage to property.

To ensure a safe, proper, and economical operation of the Condair Vita Power, please observe and comply with all information and safety instructions contained in the present documentation as well as in the separate documentations of the components used together with the Condair Vita Power water.

If you have questions after reading this documentation, please contact your Condair representative. He will be glad to assist you.

## 1.2 Notes on the installation manual

### Limitation

**The subject of this installation manual is the Condair Vita Power in its different versions.** The various options and accessories are only described insofar as is necessary for proper installation of the equipment. Further information on options and accessories can be obtained in the respective instructions.

This installation manual is restricted to the **installation** of the Condair Vita Power and is meant for **well trained personnel being sufficiently qualified for their respective work.**

The installation manual is supplemented by various separate items of documentation (e.g. operation manual, spare parts list, etc.), which are included in the delivery as well. Where necessary, appropriate cross-references are made to these publications in the installation manual.

## Symbols used in this manual



### CAUTION!

The catchword "CAUTION" used in conjunction with the general caution symbol designates notes in this installation manual that, if neglected, may cause **damage and/or malfunction of the unit or other material assets**.



### WARNING!

The catchword "WARNING" used in conjunction with the general caution symbol designates safety and danger notes in this installation manual that, if neglected, may cause **injury to persons**.



### DANGER!

The catchword "DANGER" used in conjunction with the general caution symbol designates safety and danger notes in this installation manual that, if neglected, may lead to **severe injury or even death of persons**.

## Safekeeping

Please safeguard this installation manual in a safe place, where it can be immediately accessed. If the equipment changes hands, this installation manual must be passed on to the new operator.

If the installation manual gets mislaid, please contact your Condair representative.

## Language versions

This installation manual is available in various languages. Please contact your Condair representative for information.

## 2 For your safety

---

### General

Every person working with the Condair Vita Power must have read and understood the Condair Vita Power installation manual and the Condair Vita Power operation manual before carrying out any work. Knowing and understanding the contents of these manuals is a basic requirement for protecting personnel against any kind of danger, to prevent faulty operation, and to operate the Condair Vita Power safely and correctly.

All icons, signs and markings applied to the components of the Condair Vita Power must be observed and kept in readable state.

### Qualification of personnel

All work described in the Condair Vita Power installation manual **may only be carried out by specialists who are well trained and adequately qualified and are authorized by the customer.**

For safety and warranty reasons any action beyond the scope of this manual must be carried out only by trained service personnel authorized by Condair.

For VDI-certified systems, the personnel must meet the following qualifications:

- For general installation, maintenance and inspection work:  
Completed training according to **VDI 6022 Sheet 6, Qualification category B**
- For hygiene-relevant work during planning, installation, commissioning, operation and maintenance as well as for hygiene inspections:  
Completed training according to **VDI 6022 Sheet 6, Qualification category A**

It is assumed that all persons working with the Condair Vita Power are familiar and comply with the appropriate regulations on work safety and the prevention of accidents.

### Intended use

The Condair Vita Power high pressure water treatment system is intended **to be used exclusively for pure water or ultra pure water production for the supply of Condair isothermal or adiabatic humidifiers within the operating conditions as specified.** Any other use without the written consent of Condair, is considered as not conforming with the intended purpose and may lead to the Condair Vita Power becoming dangerous and will void any warranty.

Operation of the equipment in the intended manner requires **that all the information contained in Condair Vita Power installation manual and the Condair Vita Power operation manual are observed (in particular the safety instructions).**

## Danger that may arise from the Condair Vita Power



**DANGER!**  
Risk of electric shock!

**The Condair Vita Power is mains powered. Live parts may be exposed when components of the system are opened. Touching live parts may cause severe injury or danger to life.**

**Prevention:** The system (System Master) must not be connected to the power supply until all mounting and installation work has been completed and checked for correct workmanship. It must also be ensured that all covers (System Master, External control unit, water treatment units, etc.) are correctly attached and secured.



**DANGER!**  
Health risk because of inadequate hygiene!

**Inadequately operated and/or poorly maintained pure water systems may endanger health.**

**Prevention:** The Condair Vita Power must strictly be operated and maintained in accordance with this manual.



**DANGER!**  
Health risk!

**Due to health risks, the silicate content in the supply water – in any form – must not exceed 12 mg/l.**

If the silicate content of the supply water is higher a silicate filter must mandatory be installed in the water supply line before the Condair Vita Power by the customer.

For product specific limitations for silicate please observe the required preconditions for the water supply.



**WARNING!**

**To prevent water stagnation and microbial contamination, the power supply to the Condair Vita Power should be left switched on. If the system is switched off for more than 72 hours, the pipe work and system must be disinfected as per the instructions, and a full risk assessment must be undertaken to ensure safe operation.**



**WARNING!**

Do not use oil, grease, glue, Teflon, silicone, O-ring lubrication, etc. when assembling pipes or hose connections. All of these products can lead to the growth of bacteria and thus pose health risks.

Only approved lubricant is: **Dishwashing liquid.**

When fitting water filters, RO membranes, hoses and other components in direct contact with water, wash your hands and wear sterile disposable gloves or touch only the packing foil to keep the filter and RO membranes bacteria-free.

**Do not remove** dust protection caps on pipe and hose ends until just before assembly.



**DANGER!**  
**Handling carbon dioxide!**

**In the event of a fault in the carbon dioxide-carrying connections, the breathing air in the room can be displaced by escaping carbon dioxide (CO<sub>2</sub>). There is a risk of suffocation!**

**Prevention:** Before connecting the CO<sub>2</sub> compressed gas cylinder ensure that the room is adequately ventilated. After replacing the CO<sub>2</sub> compressed gas cylinder, ensure that there are no leaks. If any are found, repair them immediately. The safety regulations for handling compressed gas containers, especially gas containers filled with carbon dioxide (CO<sub>2</sub>), must be observed and adhered to.

For safety reasons, we strongly recommend installing a CO<sub>2</sub> sensor in the room, which will trigger an alarm in the event of a CO<sub>2</sub> leak.

---

### **Correct lifting and handling**

Lifting or handling of components always carries an element of risk, and therefore must only be carried out by trained and qualified personnel. Ensure that any lifting operations have been fully planned and risk assessed. All equipment should be checked by a skilled and competent health & safety representative.

It is the customer's responsibility to ensure that operators are trained in handling heavy goods and to enforce the relevant lifting regulations.

### **Preventing unsafe operation**

All persons working with the Condair Vita Power are obliged to report any alterations to the system and the associated installations that may affect safety to the owner without delay and to **secure the Condair Vita Power against accidental power-up**.



**CAUTION!**

In order that the Condair Vita Power does not remain in the error status unnoticed for a longer period of time in the event of a malfunction, errors must be signaled via a remote error indication (e.g. via the error relay of the optional remote operating and fault indication board or via the network via BACnet or Modbus).

---

### **Prohibited modifications to the unit**

**No modifications must be undertaken** on the Condair Vita Power without the express written consent of the manufacturer. If necessary, contact your Condair representative.

For the replacement of defective components use exclusively **original accessories and spare parts** available from your Condair representative.

# 3 Product overview

## 3.1 Model overview

The Condair Vita Power is available in different models for different purposes and three different capacities 100 l/hr, 300 l/hr, 0 l/hr. The Condair Vita Powers is delivered ready for connection.

Model	Water treatment units				
	RO Reverse osmosis	DI Deionization	CO CO <sub>2</sub> enrichment	UV UV reactor	HP High Pressure
Condair Vita Power RO-DI-CO-UV-HP	X	X	X	X	X
Condair Vita Power RO-UV-HP	X			X	X
Condair Vita Power UV-HP				X	X
Condair Vita Power RO	X				

Depending on the model and the supply water quality the Condair Vita Power must be supplemented by additional upstream components (water softener, dechlorination, etc.).

## 3.2 Product designation

The product identification and the most important device data can be found on the rating plates fixed to the left side of the System Master of the Condair Vita Power.

The diagram shows a rating plate with the following callouts and data:

- Device type**: Condair Vita Power RO-DI-CO-UV-HP
- Serial number**: Ser.No: XXXXXXXX
- Manufacturing date month/year**: 10.25
- Supply voltage**: Voltage: 400 VAC 3~ / 50Hz
- Production capacity**: Capacity: 500 l/h
- Admissible water supply pressure (yield pressure)**: Inlet pressure: 2.5 - 4 bar
- Certificates**: CE, DEGUV Test, IP 21, and a warning triangle.
- Unit designation**: Condair Vita
- Power consumption**: El. Power: 3.8 kVA / 5.8 A

Additional information on the plate includes: Condair Group AG, Gwattstrasse 17, 8808 Pfäfers SZ, Switzerland and Engineered in Switzerland, Made in Germany.

### 3.3 System overview Condair Vita Power RO-DI-CO-UV-HP

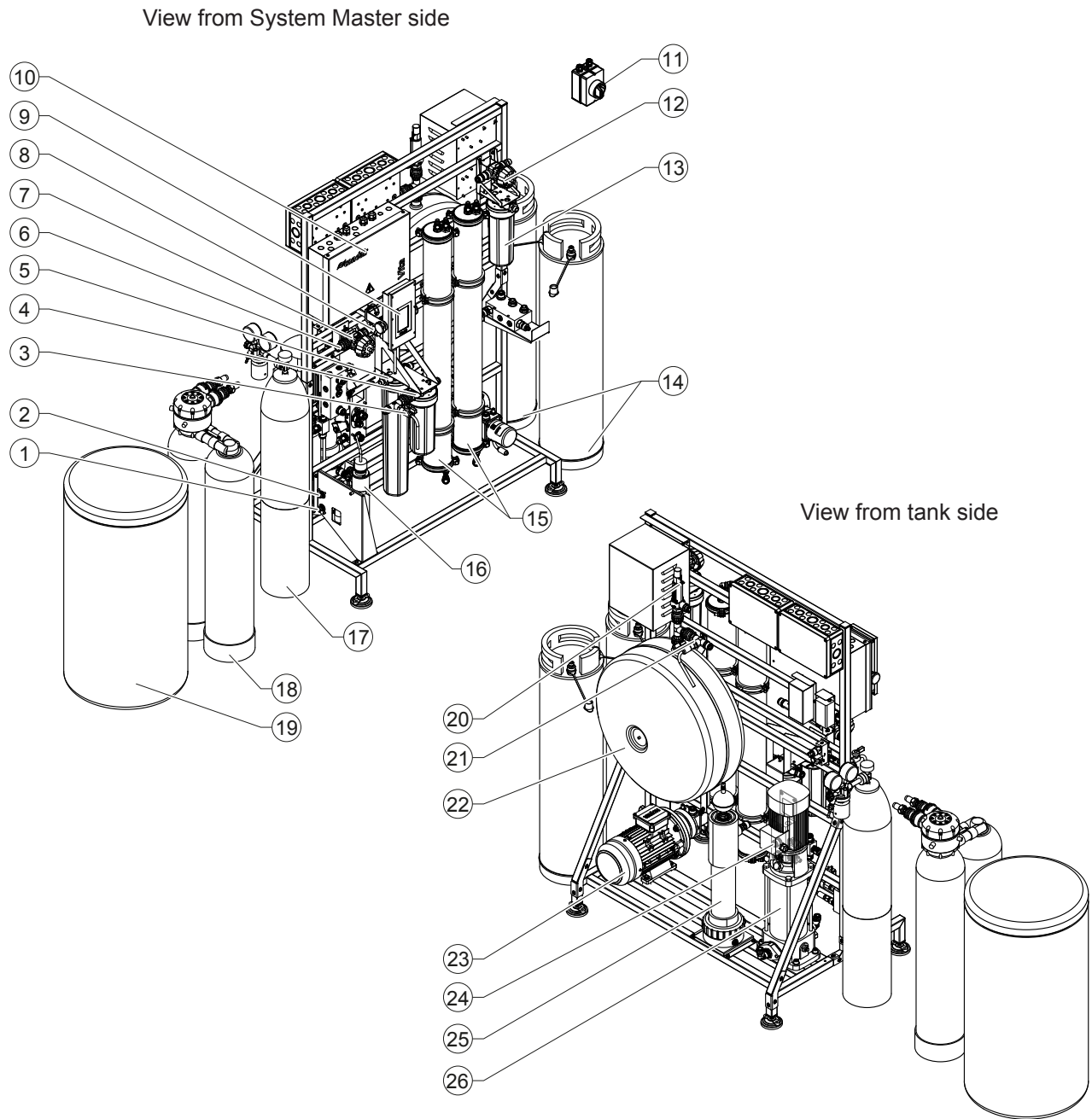

Fig. 1: System overview Condair Vita Power RO-DI-CO-UV-HP (image shows 500 l/hr version)

- |    |   |    |  |
|----|---|----|--|
| 1  | Outlet connector high pressure  | 15 | Reverse osmosis membranes  |
| 2  | Return connector high pressure  | 16 | UV reactor   |
| 3  | Sampling tap before high pressure pump (optional, sanitizable by flame) | 17 | CO <sub>2</sub> compressed gas cylinder with pressure reducing valve     |
| 4  | Micro particle filter 5 µm before high pressure pump                    | 18 | Water softener (optional, recommended)                                   |
| 5  | Micro particle filter 5 µm (pre-filter)                                 | 19 | Salt container water softener  |
| 6  | Water supply connection G 3/4"  | 20 | Safety valve pressure tank   |
| 7  | Manual shut-off valve water inlet                                       | 21 | Sampling tap supply after pressure tank (optional, sanitizable by flame) |
| 8  | Sampling tap supply water inlet (sanitizable by flame)                  | 22 | Pressure tank  |
| 9  | External control unit   | 23 | High pressure pump   |
| 10 | System Master   | 24 | Water drain connection   |
| 11 | Electrical isolator (by client)   | 25 | CO <sub>2</sub> -mixing unit   |
| 12 | Manual shut-off valve before deionizing cartridges                      | 26 | Reverse osmosis pump   |
| 13 | Micro particle filter 5 µm after deionizing cartridges                  |    |  |
| 14 | Deionizing cartridges   |    |  |

### 3.4 System overview Condair Vita Power RO-UV-HP

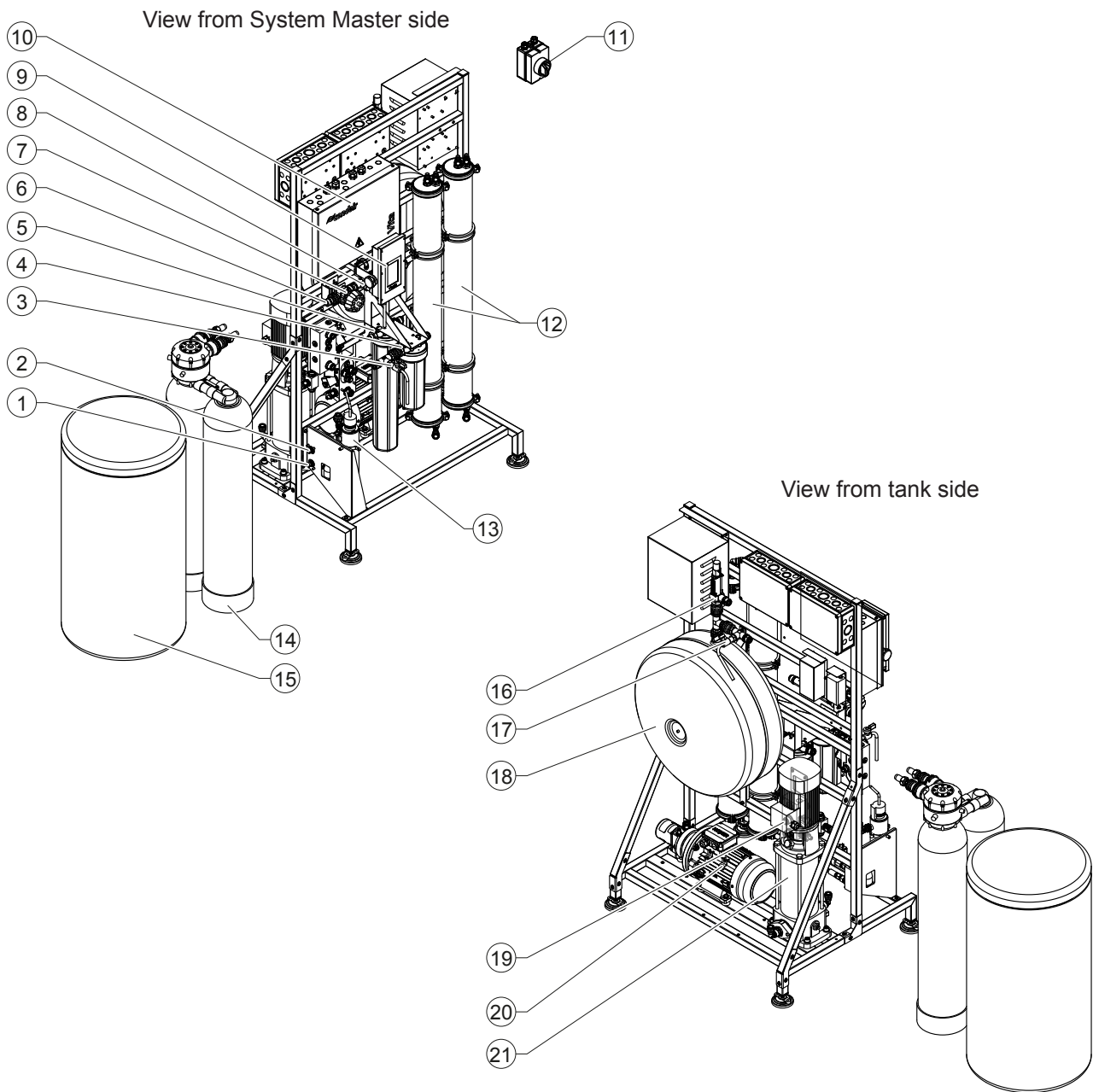

Fig. 2: System overview Condair Vita Power RO-UV-HP (image shows 500 l/hr version)

- |    |   |    |  |
|----|---|----|--|
| 1  | Outlet connector high pressure  | 12 | Reverse osmosis membranes  |
| 2  | Return connector high pressure  | 13 | UV reactor   |
| 3  | Sampling tap before high pressure pump (optional, sanitizable by flame) | 14 | Water softener (optional, recommended)                                   |
| 4  | Micro particle filter 5 µm before high pressure pump                    | 15 | Salt container water softener  |
| 5  | Micro particle filter 5 µm (pre-filter)                                 | 16 | Safety valve pressure tank   |
| 6  | Water supply connection G 3/4"  | 17 | Sampling tap supply after pressure tank (optional, sanitizable by flame) |
| 7  | Manual shut-off valve water inlet                                       | 18 | Pressure tank  |
| 8  | Sampling tap supply water inlet (sanitizable by flame)                  | 19 | Water drain connection   |
| 9  | External control unit   | 20 | High pressure pump   |
| 10 | System Master   | 21 | Reverse osmosis pump   |
| 11 | Electrical isolator (by client)   |    |  |

### 3.5 System overview Condair Vita Power UV-HP

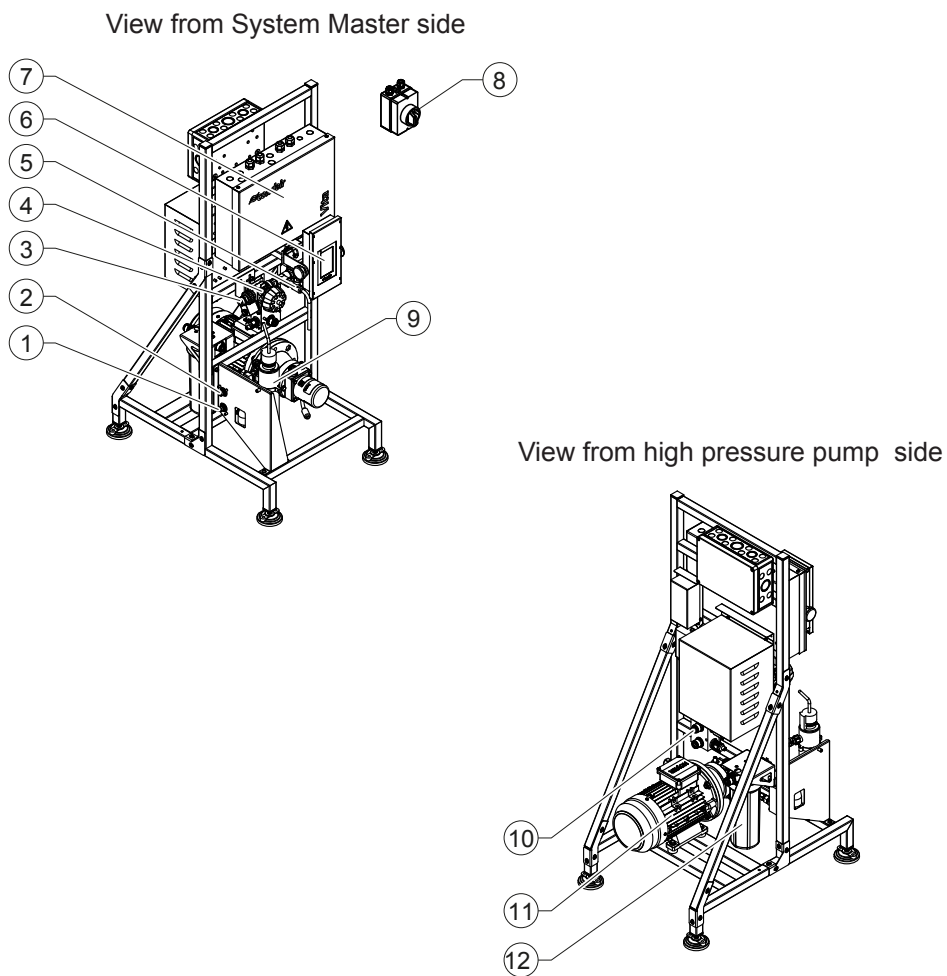

Fig. 3: System overview Condair Vita Power UV-HP (image shows 500 l/hr version)

- |   |   |    |  |
|---|---|----|--|
| 1 | Outlet connector high pressure                  | 7  | System Master  |
| 2 | Return connector high pressure                  | 8  | Electrical isolator (by client)                      |
| 3 | Water supply connection G 3/4"                  | 9  | UV reactor   |
| 4 | Manual shut-off valve water inlet               | 10 | Water drain connection                               |
| 5 | Sampling tap water inlet (sanitizable by flame) | 11 | High pressure pump                                   |
| 6 | External control unit                           | 12 | Micro particle filter 5 µm before high pressure pump |

### 3.6 System overview Condair Vita Power RO

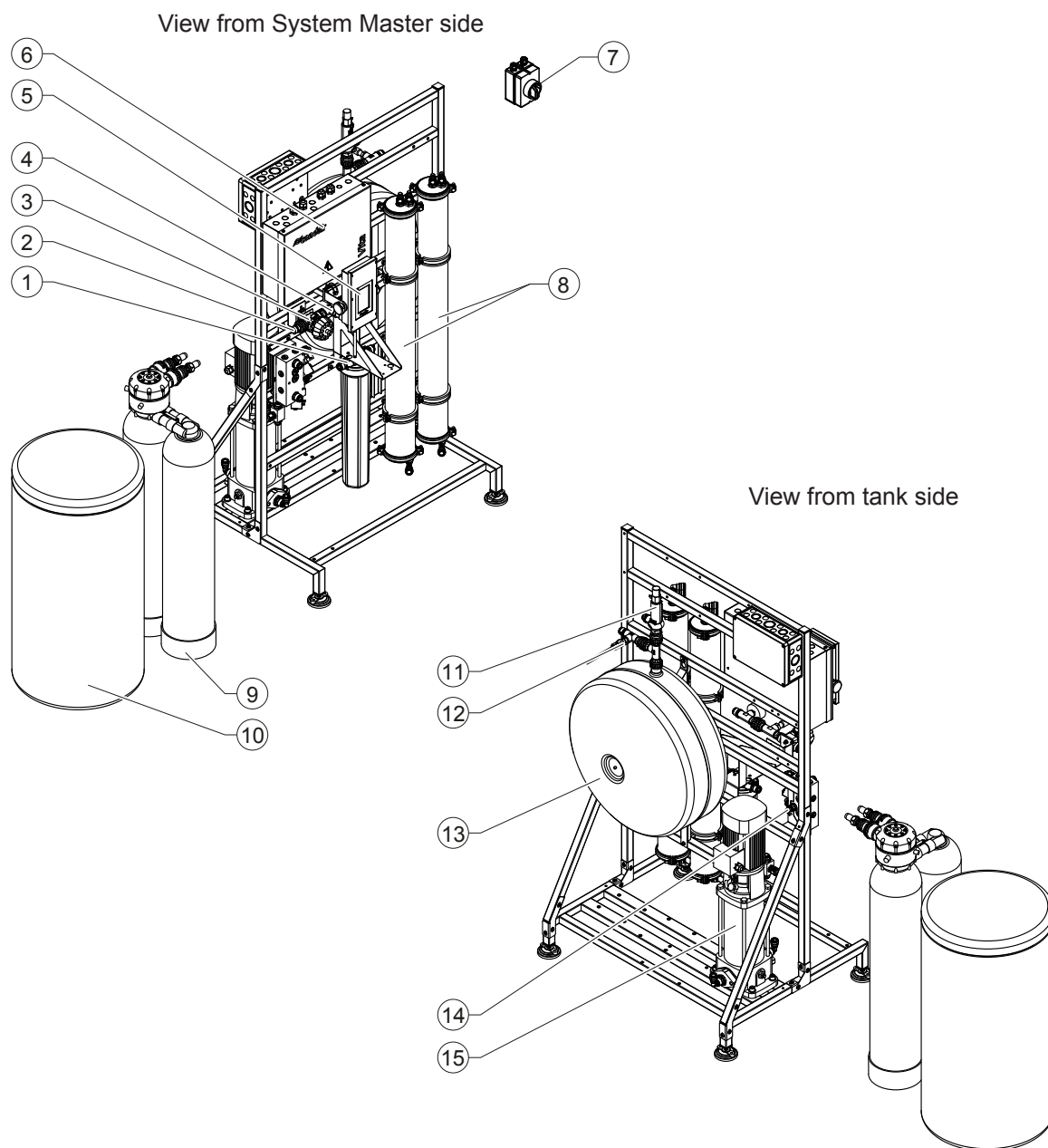

Fig. 4: System overview Condair Vita Power RO (image shows 500 l/hr version)

- |   |   |    |  |
|---|---|----|--|
| 1 | Micro particle filter 5 µm                      | 9  | Water softener (optional, recommended)                                   |
| 2 | Water supply connection G 3/4"                  | 10 | Salt container water softener  |
| 3 | Manual shut-off valve water inlet               | 11 | Safety valve pressure tank   |
| 4 | Sampling tap water inlet (sanitizable by flame) | 12 | Sampling tap supply after pressure tank (optional, sanitizable by flame) |
| 5 | External control unit                           | 13 | Pressure tank  |
| 6 | System Master                                   | 14 | Water drain connection   |
| 7 | Electrical isolator (by client)                 | 15 | Reverse osmosis pump   |
| 8 | Reverse osmosis membranes                       |    |  |

Note: The Condair Vita Power RO does not have a high pressure stage.

### 3.7 Options

	Condair Vita Power				SAP number
	RO-DI-CO-UV-HP	RO-UV-HP	UV-HP	RO	
Floor leak sensor monitors the installation room for leaks. If the leak sensor detects water on the floor the Condair Vita Power is automatically stopped. The floor leak sensor is connected to the System Master.	X	X	X	X	2613080
Remote operating and fault indication PCB with relay contacts for the connection of remote indication for "Error", "Service", "Running" and "Unit On". The remote operating and fault indication PCB is installed and connected in the System Master.	X	X	X	X	2601466
Additional sampling tap to be installed to the pressure tank outlet (see <a href="#">Fig. 1</a> , <a href="#">Fig. 2</a> and <a href="#">Fig. 3</a> ).					
100 l/hr	X	X	X		2614426
300 l/hr / 500 l/hr	X	X	X		2614427
Additional sampling tap to be installed to the outlet of the micro particle filter before the high pressure pump (see <a href="#">Fig. 1</a> , <a href="#">Fig. 2</a> and <a href="#">Fig. 3</a> ).	X	X			2613478

### 3.8 Accessories

	Condair Vita Power				SAP number
	RO-DI-CO-UV-HP	RO-UV-HP	UV-HP	RO	
Water softener for systems with 100 l/hr					
Single softener SoftCab DR25C EF	X	X		X	2616058
Accessories set SoftCab DR25C EF	X	X		X	2613583
Water softener for systems with 300 l/hr and 500 l/hr					
Double water softener DSP25 EF	X	X		X	2616051
Accessories set SoftCab DSP25 EF	X	X		X	2613606
Double water softener S150 XP	X	X		X	2613349
Accessories set S150 XP	X	X		X	2613582
Shut-off valve - 3/4"	X	X	X	X	2611732
System separator - 3/4"	X	X	X	X	2613653
Pressure reducing valve - 3/4"	X	X	X	X	2611730

## 4 Receiving and storage

### 4.1 Inspection

After receiving:

- Inspect shipping boxes for damage.  
Any damages to the shipping boxes must be reported to the shipping company.
- Check packing slip to ensure all parts has been delivered.  
All material shortages are to be reported to your Condair representative within 48 hours after receipt of the goods. Condair assumes no responsibility for any material shortages beyond this period.
- Unpack the parts/components and check for any damage.  
It is particularly important that the pressure tank, frame construction, and fixings (such as studs) are inspected as damage to these items could affect the structural integrity of the system. If parts/components are damaged, notify the shipping company immediately.
- Check whether the components are suitable for installation on your site according to the product specification.

### 4.2 Storage and Transportation

#### Storing

Until installation store the Condair Vita Power and other system components in their original packaging in a protected area meeting the following requirements:

- Room temperature: 5 ... 40 °C
- Room humidity: 10 ... 75 %rh

#### Transportation

For optimum protection always transport the Condair Vita Power and any other system components in their original packaging and use appropriate transporting/lifting devices.



#### **WARNING!**

It is the customer's responsibility to ensure that operators are trained in handling heavy goods and that the operators comply with the appropriate regulations on work safety and the prevention of accidents.

#### Packaging

In case you wish to dispose of the packaging, observe the local regulations on waste disposal. Please recycle packaging where possible.

# 5 Installation

## 5.1 Safety notes on mounting and installation work

### Qualification of personnel

All mounting and installation work may only be carried out by technically qualified and appropriately trained personnel authorized by Condair. It is the owner's responsibility to verify proper qualification of the personnel.

All electrical installations may only be carried out by a Condair service technician or an electrician authorized by Condair.

### General notes

Strictly observe and comply with all information given in the present installation and operation manual regarding the positioning and mounting of the Condair Vita Power system components and the water and electrical installations.

Observe and comply with all local regulations dealing with water and electrical installations.

### Safety

Some installation work requires removal of the unit covers. Please note the following:



**DANGER!**  
Risk of electric shock!

**The Condair Vita Power is mains powered. Live parts may be exposed when components of the system are opened. Touching live parts may cause severe injury or danger to life.**

**Prevention:** The system (System Master) must not be connected to the power supply until all mounting and installation work has been completed and checked for correct workmanship. It must also be ensured that all covers (System Master, External control unit, water treatment units, etc.) are correctly attached and secured.



**CAUTION!**

The electronic components inside the System Master are sensitive to electrostatic discharge. Before carrying out installations work inside System Master, appropriate measures must be taken to protect the electronic components against damage caused by electrostatic discharge (ESD protection).



**WARNING!**  
Ensure hygiene!

To ensure that the system remains dry until commissioning and is not contaminated by standing water, the water supply line must not be connected to the inlet connection of the Condair Vita Power until commissioning.

## 5.2 Installation room requirements

The Condair Vita Power is designed for installation in protected interior spaces. Please note the following information regarding the requirements for the installation space:

- All components of the Condair Vita Power must be installed in a interior room that is only accessible to authorized persons.
- The room should be equipped with a **floor drain** or a **lifting system (wastewater pump)** that is connected to the building waste water line.
- To connect the drain pipe from the Condair Vita Power to the building waste water line, an open drain funnel with trap must be present at a suitable location in the room (see [Fig. 14 on page 32](#)).
- The installation room should be ventilated and have the following temperature and humidity values throughout the year:
  - Room temperature: +15 °C to +25 °C
  - Room humidity: 15% RH to 80% RH (non-condensing)

Note: Higher room temperatures increase water consumption due to more frequent hygiene flushes.
- There must be enough space at the installation site so that the components of the Condair Vita Power water treatment can be correctly placed and there is enough space for the operation and maintenance of the system (see system dimensions in [Section 5.4](#)).
- The components of the Condair Vita Power must be mounted in the room in such a way that the components can be connected using the hoses provided (see [Fig. 12 on page 30](#) to [Fig. 14 on page 32](#) an the system dimensions in [Section 5.4](#)).
- The installation room must be equipped with:
  - a 400 VAC / 3~N / 50 Hz mains connection (L1, L2, L3 and N),
  - an RJ45 LAN connection (recommended), and
  - a drinking water connection with sufficient supply capacity (required supply capacities see [Section 7.1](#)).

### 5.3 Positioning and mounting instructions

Basically, the positioning of the components of the Condair Vita Power is determined during planning and recorded in the system documents. In any case, the following general positioning instructions must be observed and adhered to:

- The installation must be carried out in accordance with the general technical rules and the connection regulations of the local utility companies.
- Make sure that the floor of the room on which the system components are to be mounted has sufficient load-bearing capacity and is suitable for fastening.
- The system components should be mounted in such a way that there is enough space for maintenance and operation (see system dimensions in [Section 5.4](#)).
- No unauthorized modifications or changes may be made to the components of the Condair Vita Power.
- No additional fittings (e.g. valves, etc.) that are not noted in these instructions may be installed within the Condair Vita Power.
- These assembly instructions refer to the Condair Vita Power.
- While maintaining the maximum dimensions (see images in [Section 5.4](#)), the components of the Condair Vita Power (Water softener, Condair Vita Power, deionizing cartridges and CO<sub>2</sub> compressed gas cylinder) can be placed individually in the room.
- The system components of the Condair Vita Power should, if possible, be installed on the same level and in the same room.
- The CO<sub>2</sub> compressed gas cylinder must be placed in such a way that it can be secured against tipping over using suitable means and can be easily replaced.

## 5.4 System dimensions

### 5.4.1 System dimensions Vita Power RO-DI-CO-UV-HP

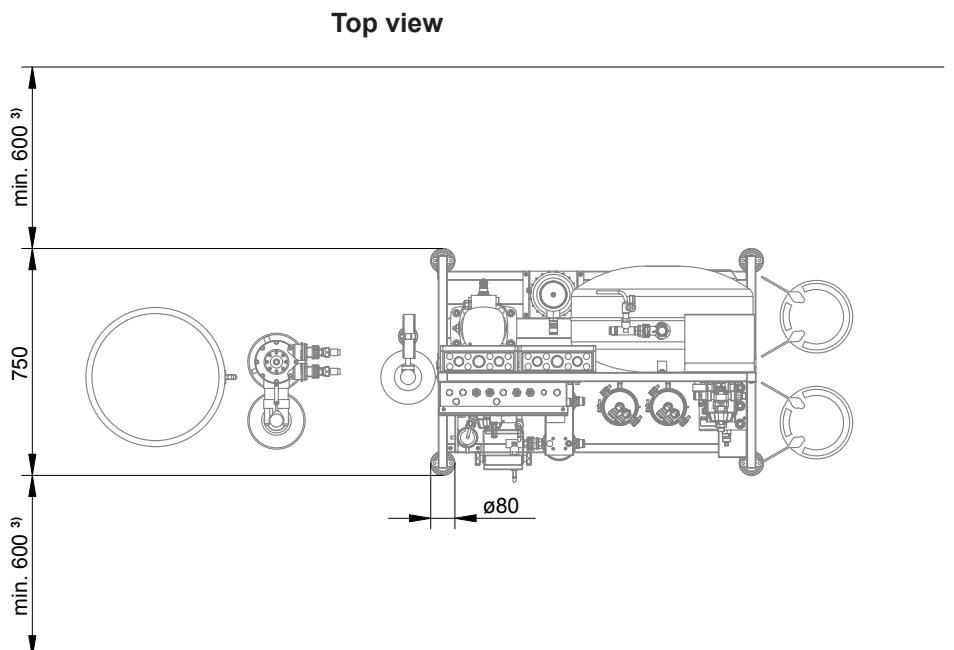
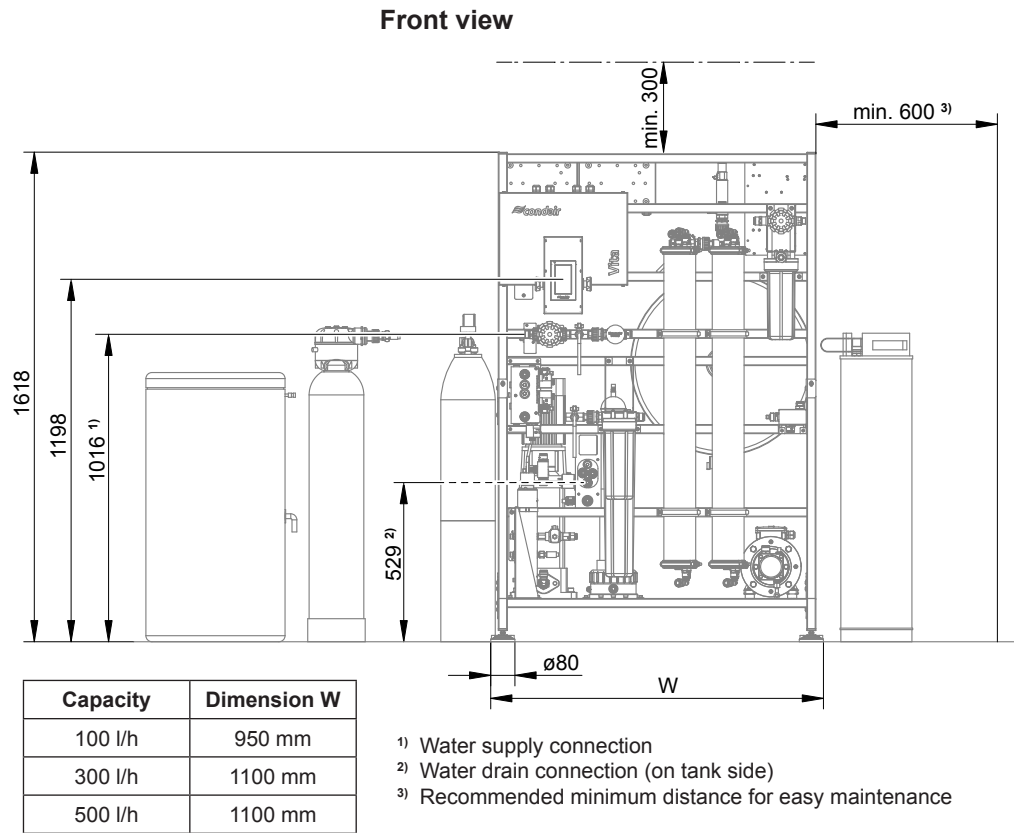

Fig. 5: System dimensions Vita Power RO-DI-CO-UV-HP (dimensions in mm)

## 5.4.2 System dimensions Vita Power RO-UV-HP

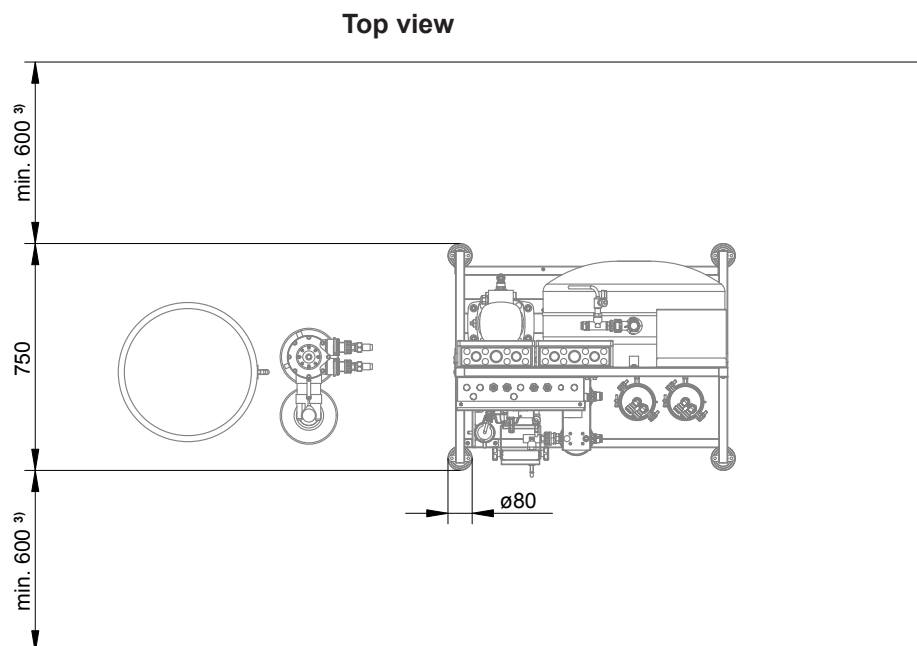
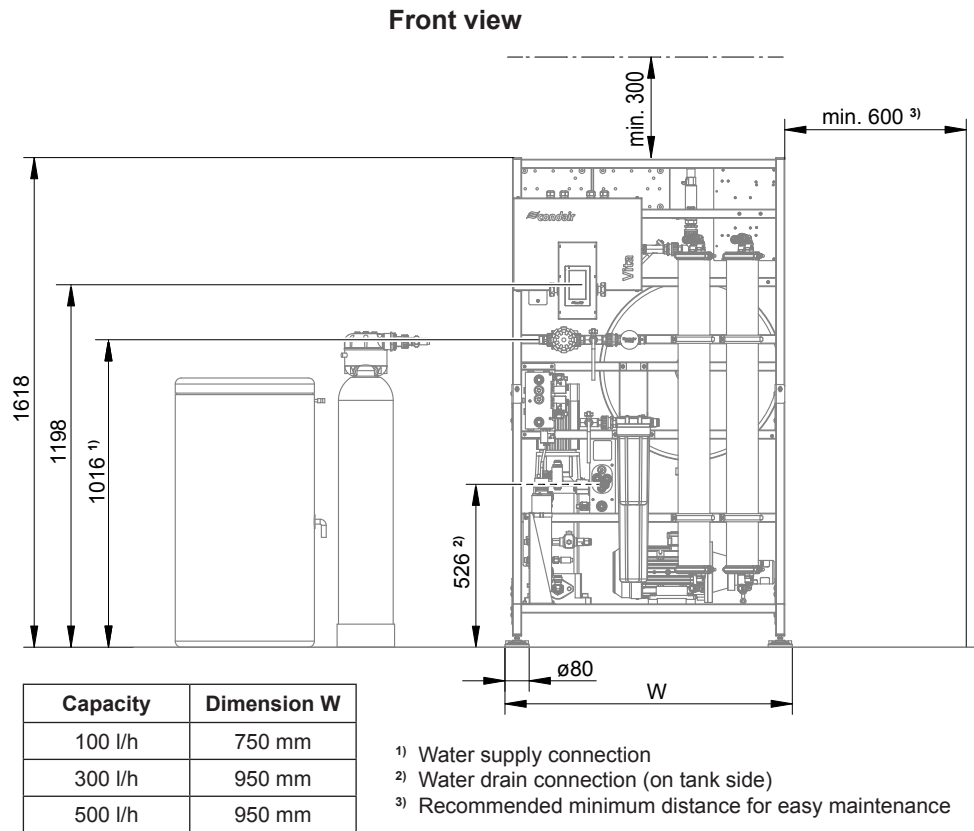
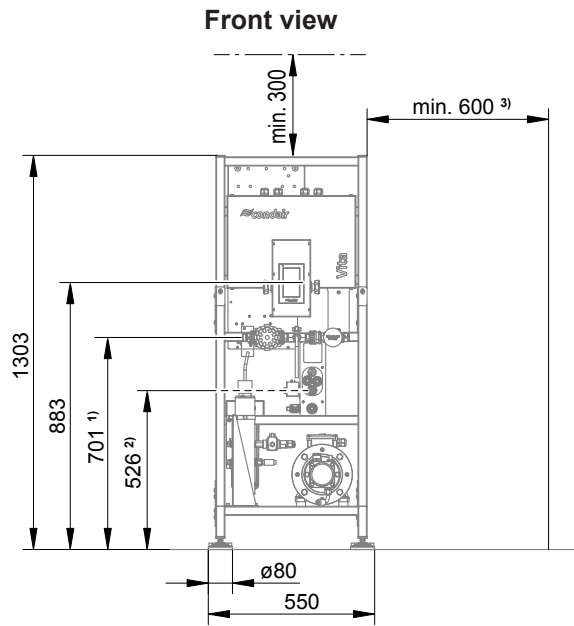

Fig. 6: System dimensions Vita Power RO-UV-HP (dimensions in mm)

### 5.4.3 System dimensions Vita Power UV-HP



- 1) Water supply connection
- 2) Water drain connection (on pump side)
- 3) Recommended minimum distance for easy maintenance

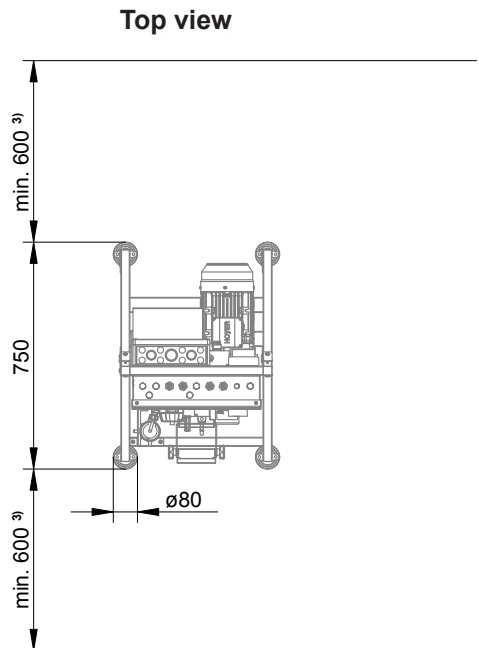

Fig. 7: System dimensions Vita Power RO-UV-HP (dimensions in mm)

## 5.4.4 System dimensions Vita Power RO

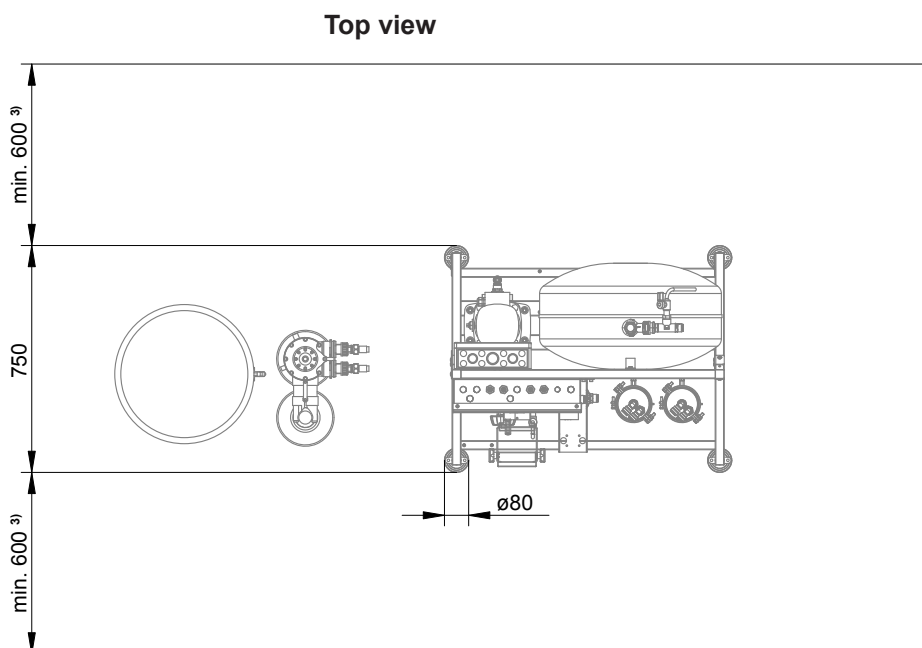
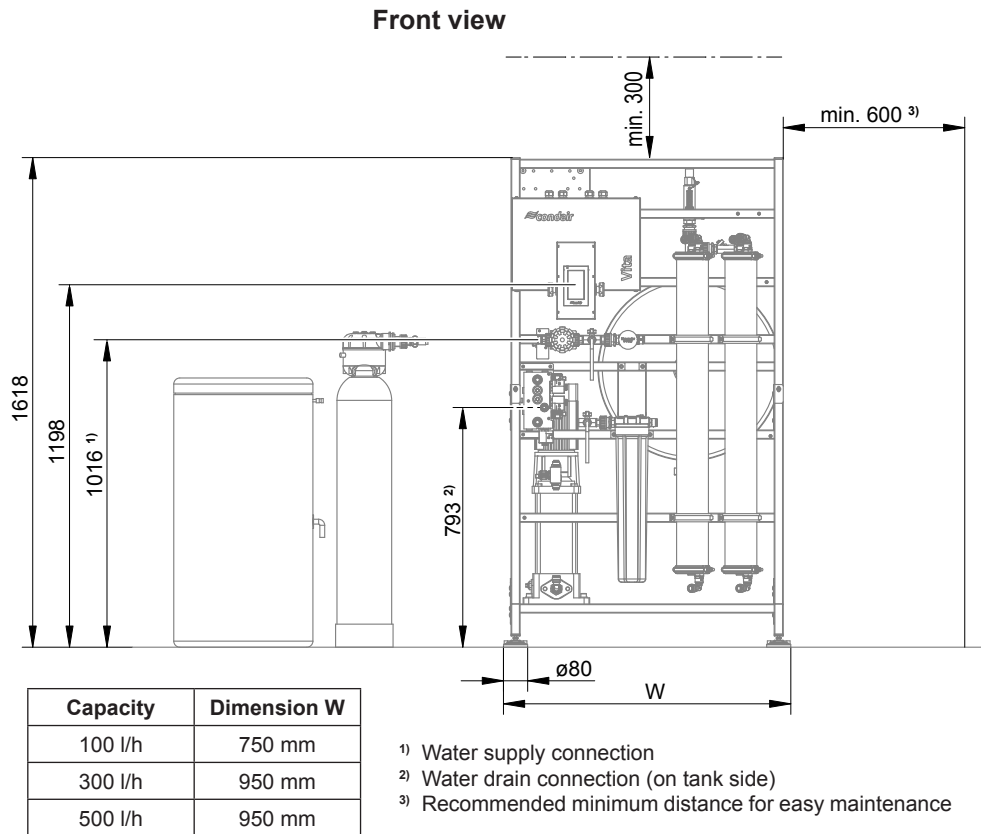

Fig. 8: System dimensions Vita Power RO (dimensions in mm)

## 5.5 Mounting of the components of the Condair Vita Power

### 5.5.1 Mounting of Condair Vita Power

Note: The following description for installing the Condair Vita Power applies to all models. Please observe the system dimensions of the individual models (see [Fig. 5](#) to [Fig. 8](#)).

1. Place the Condair Vita Power on the floor at the desired location in the room, observing the maximum and minimum distances (see [Fig. 5](#) to [Fig. 8](#)).



#### WARNING!

**Always transport the Condair Vita Power to the desired location with the help of a second person and a pallet truck.**

2. Align the Condair Vita Power precisely horizontally lengthwise and crosswise using the leveling feet.
3. Then attach all four leveling feet to the floor using a dowel and a screw (included in the delivery).

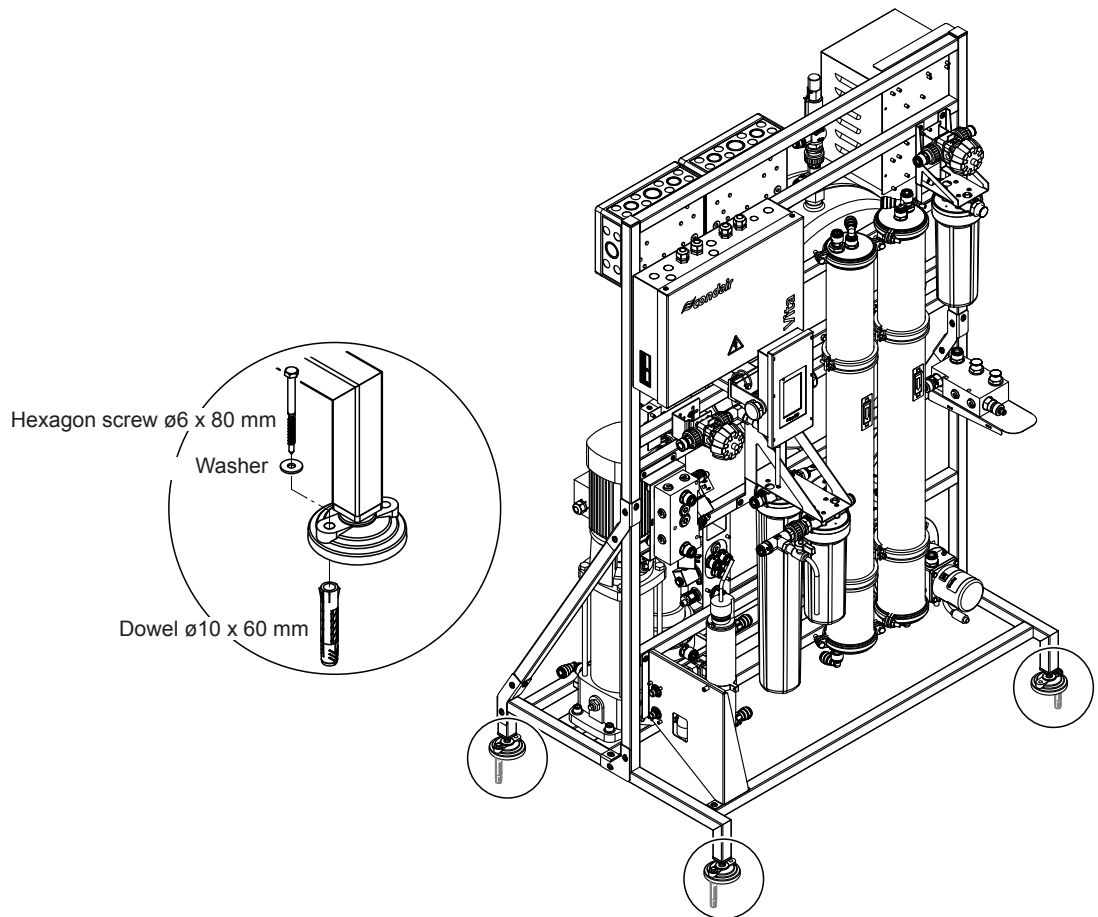

*Fig. 9: Mounting of the Condair Vita Power (image shows RO-DI-CO-UV-HP model)*

**Important:** Condair Vita Power systems are delivered without installed reverse osmosis membrane(s) and filter cartridge(s). These are delivered separately packaged with the Condair Vita Power and may only be installed during commissioning after the system has been disinfected by a Condair service technician.

## 5.5.2 Positioning and mounting of the water softener

For the placement and installation of the optional water softener for the models Condair Vita Power RO-DI-CO-UV-HP, Condair Vita Power RO-UV-HP and Condair Vita Power RO, please refer to [Fig. 5](#), [Fig. 6](#) and [Fig. 8](#) and the information and safety instructions in the separate instructions for the softener used.

**Important:** The length of the supplied reinforced hoses for connecting the water softener to the Condair Vita Power is **1.5 m**.

## 5.5.3 Positioning of the deionizing cartridges

For the positioning of the deionizing cartridges, please refer to [Fig. 5](#) and the information and safety instructions in the separate instructions for the deionizing cartridges.

**Important:** The length of the supplied reinforced hoses for connecting the deionizing cartridges to the Condair Vita Power is **1.5 m** (deionizing cartridge 1) or **2 m** (deionizing cartridge 2).

## 5.5.4 Positioning of the CO<sub>2</sub> compressed gas cylinder

For the positioning and attachment of the CO<sub>2</sub> compressed gas cylinder for the Condair Vita Power RO-DI-CO-UV-HP model, please refer to [Fig. 5](#) and the local safety instructions for handling CO<sub>2</sub> compressed gas cylinders.

Note: If the CO<sub>2</sub> compressed gas cylinder is placed to the left of the Condair Vita Power as shown in [Fig. 1](#), it can be securely attached to the frame using a chain (recommended).

**Important:** The length of the supplied John Guest (JG) hose  $\varnothing 6/4$  mm for connecting the CO<sub>2</sub> compressed gas cylinder to the Condair Vita Power is **2 m**.

## 5.6 Water installation

### 5.6.1 Important notes on water installation

- All plumbing work may only be carried out by a **Condair service technician** or **qualified personnel authorized by the owner** (e.g., a plumber with appropriate training). It is the owner's responsibility to verify proper qualification of the personnel.
- Plumbing installations must be carried out in accordance with the information in these installation manual and the applicable local regulations for plumbing installations.
- All hoses must be laid in such a way that:
  - they do not become a tripping hazard
  - they have no kinks
- All hoses must be secured or protected with suitable means to prevent them from chafing at edges during operation and from being accidentally torn off or damaged.
- All John Guest (JG) hoses must be cut straight and free of kinks using a suitable cutting tool. Burrs and sharp edges at the cut point must be removed to prevent damage to the JG couplings.

## 5.6.2 Water supply connection

Connecting the water supply to the models **Condair Vita Power RO-DI-CO-UV-HP**, **Condair Vita Power RO-UV-HP** and **Condair Vita Power RO**

The water supply is connected as shown in [Fig. 10](#) and **is the responsibility of the customer**.

**Important:** The instructions for hose routing and hose fastening in [Section 5.6.1](#) must be strictly observed and complied with.



**WARNING!**  
Ensure hygiene!

To ensure that the system remains dry until commissioning and is not contaminated by standing water, the water supply line must not be connected to the inlet connection of the Condair Vita Power until commissioning.

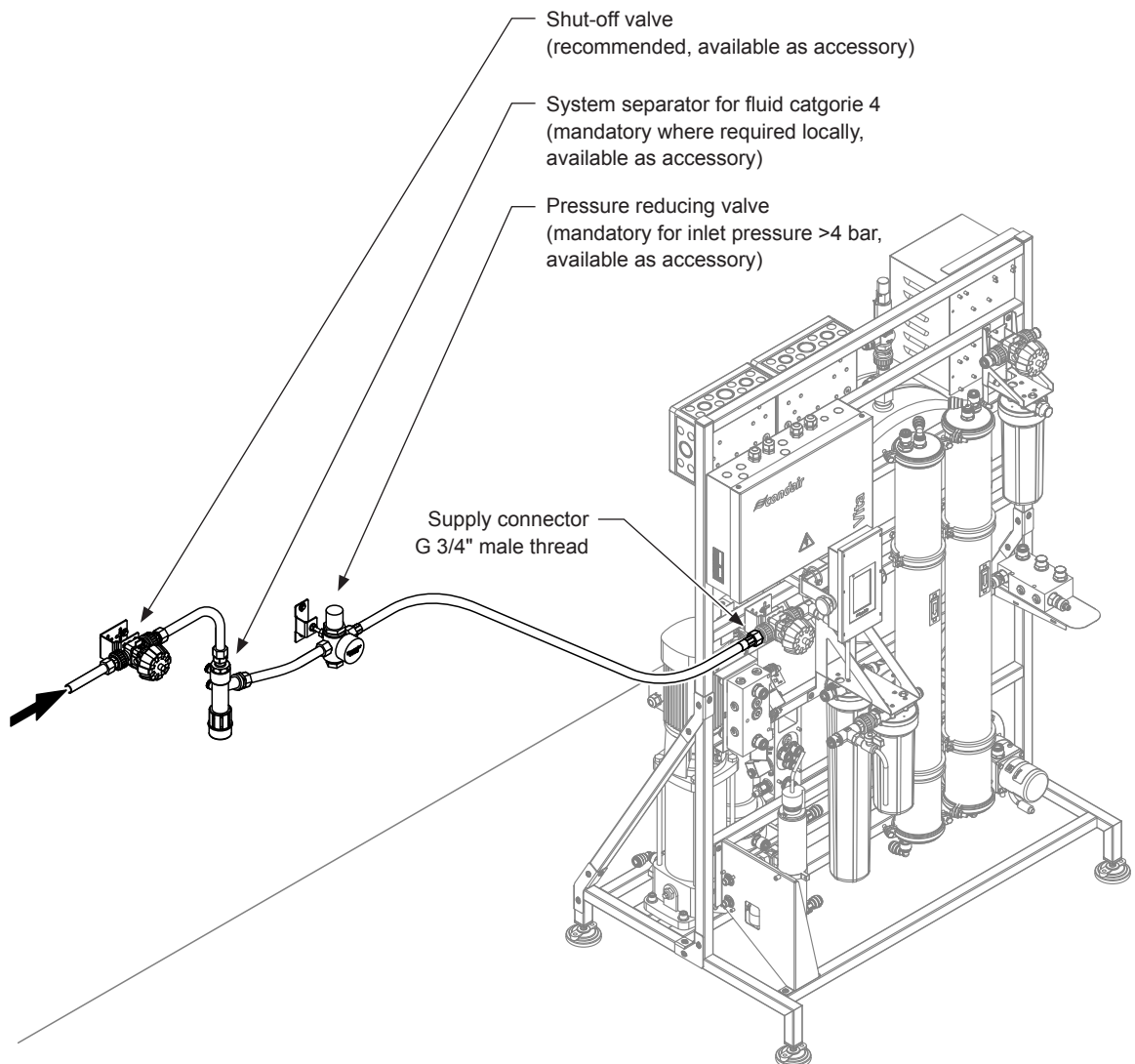

Fig. 10: Water supply connection (image shows Condair Vita Power RO-DI-CO-UV-HP 500 l/hr without water softener)

The supply water for the Condair Vita Power RO-DI-CO-UV-HP, Condair Vita Power RO-UV-HP and Condair Vita Power RO models must meet the following specifications:

Quality of the supply water	Drinking water quality in accordance with local regulations
Water supply pressure	2.5 - 4 bar
Max. water temperature	20°C
Max. pH value without water softener	8
Free chlorine	up to 0.1 mg/l <sup>2)</sup>
Silt Index (SDI)	max. 3
KMnO <sub>4</sub>	max. 10 mg/l
Fe	max. 0.2 mg/l
Mn	max. 0.05 mg/l
NTU	max. 1.0

<b>Common preconditions for the use of a water softener</b>			
<b>pH level of incoming water</b>	<b>6.5 - 7.0</b>	<b>&gt;7.0 - 7.5</b>	<b>&gt;7.5 - 8.0</b>
Max. water hardness	20 °dH <sup>1)</sup>	17 °dH <sup>1)</sup>	10 °dH <sup>1)</sup>
Max. conductivity	650 µS/cm <sup>1)</sup>	650 µS/cm <sup>1)</sup>	400 µS/cm <sup>1)</sup>
Max. TDS	800 mg/l <sup>1)</sup>	500 mg/l <sup>1)</sup>	250 mg/l <sup>1)</sup>

- <sup>1)</sup> If any of these values of the supply water are higher at related pH value, a water softener should be installed before the Condair Vita Power.
- <sup>2)</sup> If the chlorine content of the supply water is >0.1 mg/l, the customer must install an activated carbon filter with appropriate capacity in the supply line upstream of the Condair Vita Power.

## Connecting the water supply to the Condair Vita Power UV-HP models

The water supply is connected as shown in [Fig. 11](#) and is the responsibility of the customer.

**Important:** The instructions for hose routing and hose fastening in [Section 5.6.1](#) must be strictly observed and complied with.



**WARNING!**  
Ensure hygiene!

To ensure that the system remains dry until commissioning and is not contaminated by standing water, the water supply line must not be connected to the inlet connection of the Condair Vita Power until commissioning.

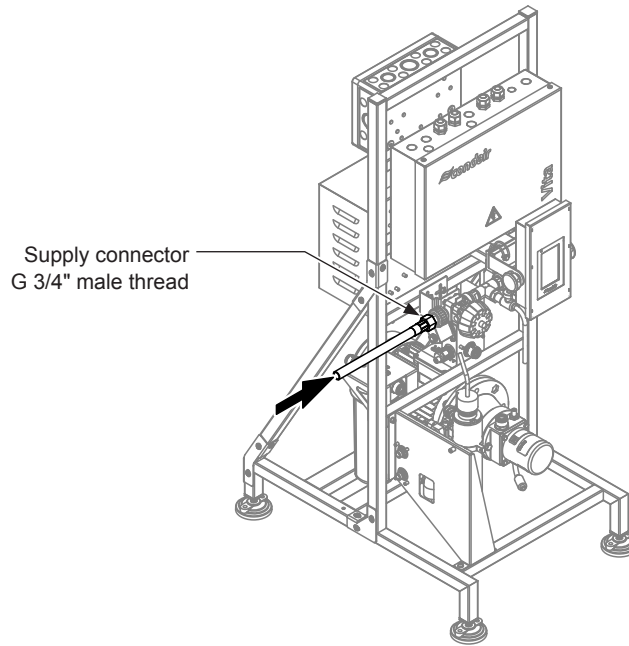

*Fig. 11: Water supply connection (image shows Condair Vita Power UV-HP 500 l/h)*

The supply water for the Condair Vita Power UV-HP model must meet the following specifications:

Quality of the supply water	Reverse osmosis water or Deionized water
Water supply pressure	2.5 - 4 bar
Max. water temperature	20°C
Conductivity	10 - 30 $\mu\text{S}/\text{cm}$
Germ count	<150 KBE/ml

### 5.6.3 Connecting the optional water softener to the Condair Vita Power

**Note:** Only for Condair Vita Power RO-DI-CO-UV-HP, RO-UV-HP and RO with optional water softener.

The supply and return lines to/from the optional water softener must be connected to the Condair Vita Power and the softener using the hoses provided as shown in [Fig. 12](#).

**Important:** The instructions for hose routing and hose fastening in [Section 5.6.1](#) must be strictly observed and complied with.

Note: To connect the supply and return lines as well as the drain and overflow lines to the optional water softener, please refer to the information in the separate instructions for the water softener.

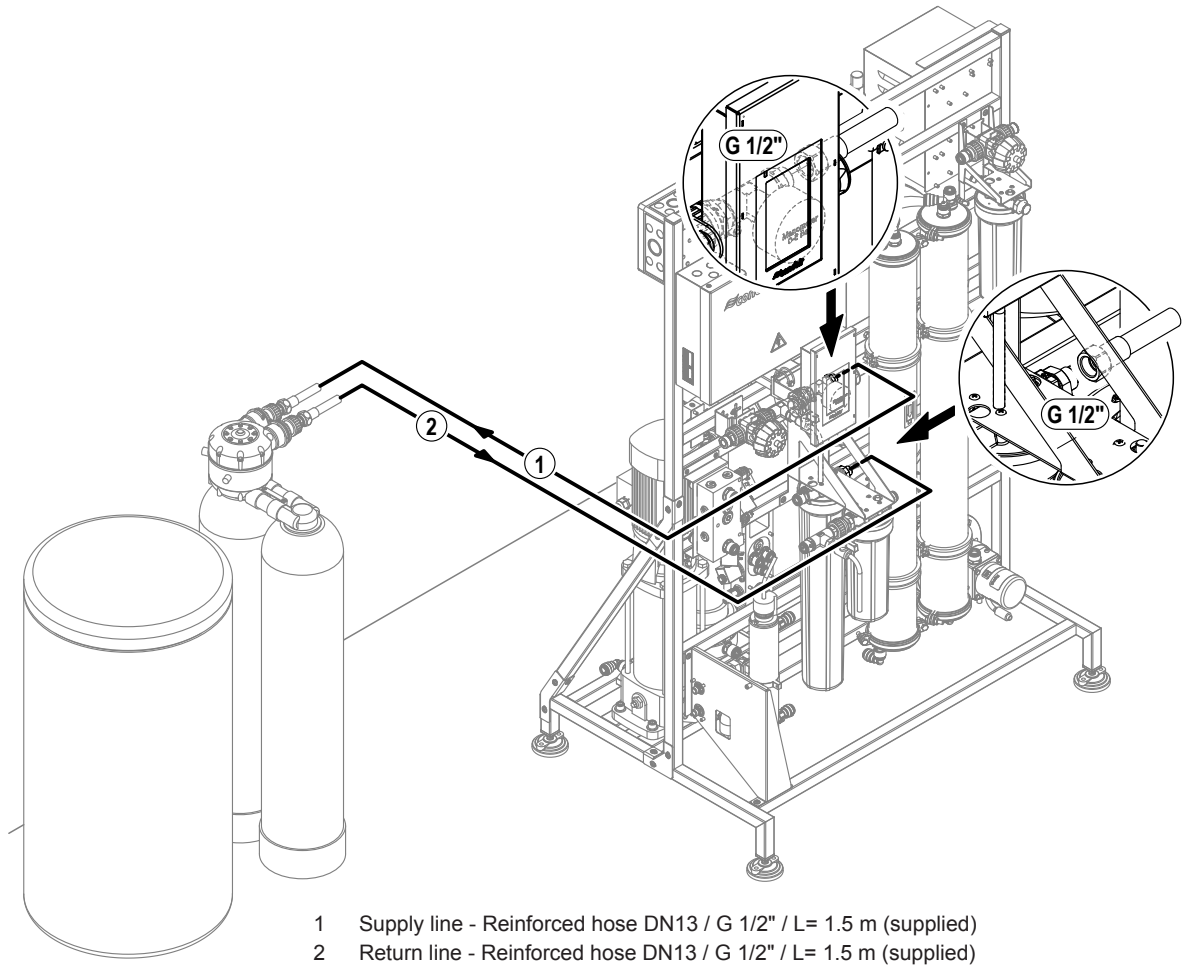

*Fig. 12: Connecting the water softener to the Condair Vita Power (image shows Condair Vita Power RO-DI-CO-UV-HP 500 l/hr)*

## 5.6.4 Connecting the deionizing cartridges to the Condair Vita Power

**Note:** Only for Condair Vita Power RO-DI-CO-UV-HP

The deionizing cartridges must be connected to the corresponding connections on the Condair Vita Power as shown in [Fig. 13](#) using the hoses provided.

**Important:** The instructions for hose routing and hose fastening in [Section 5.6.1](#) must be strictly observed and complied with.

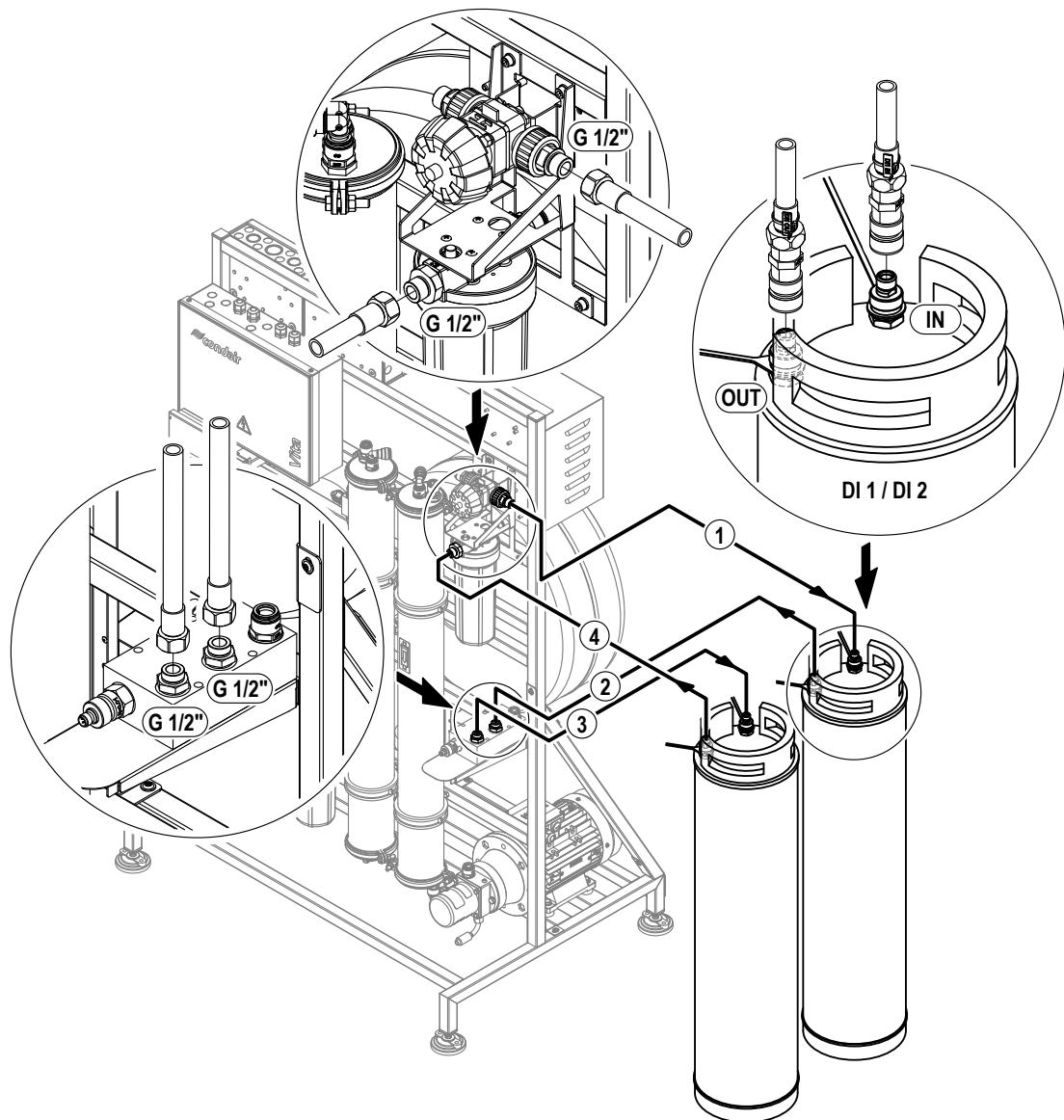

- 1 Supply line DI 1 - Reinforced hose DN13 / G 1/2" / L= 1.5 m (supplied)
- 2 Return line DI 1 - Reinforced hose DN13 / G 1/2" / L= 1.5 m (supplied)
- 1 Supply line DI 2 - Reinforced hose DN13 / G 1/2" / L= 2.0 m (supplied)
- 2 Return line DI 2 - Reinforced hose DN13 / G 1/2" / L= 1.5 m (supplied)

*Fig. 13: Connecting the deionizing cartridges to the Condair Vita Power (image shows Condair Vita Power RO-DI-CO-UV-HP 500 l/hr)*

## 5.6.5 Connecting the drain line to the Condair Vita Power

The drain line must be connected to the drain connection of the Condair Vita Power using the JG hose provided as shown in [Fig. 14](#) and then **led with a constant downslope (min. 2 %) into an open drain funnel with a trap.**

**Important:** The instructions for hose routing, hose fastening and cutting of the JG hoses in [Section 5.6.1](#) must be strictly observed and complied with.

**Important:** The drain hose must not touch the drain funnel (min. air gap 2 cm) and must be fixed directly in front of the drain funnel with a suitable bracket.

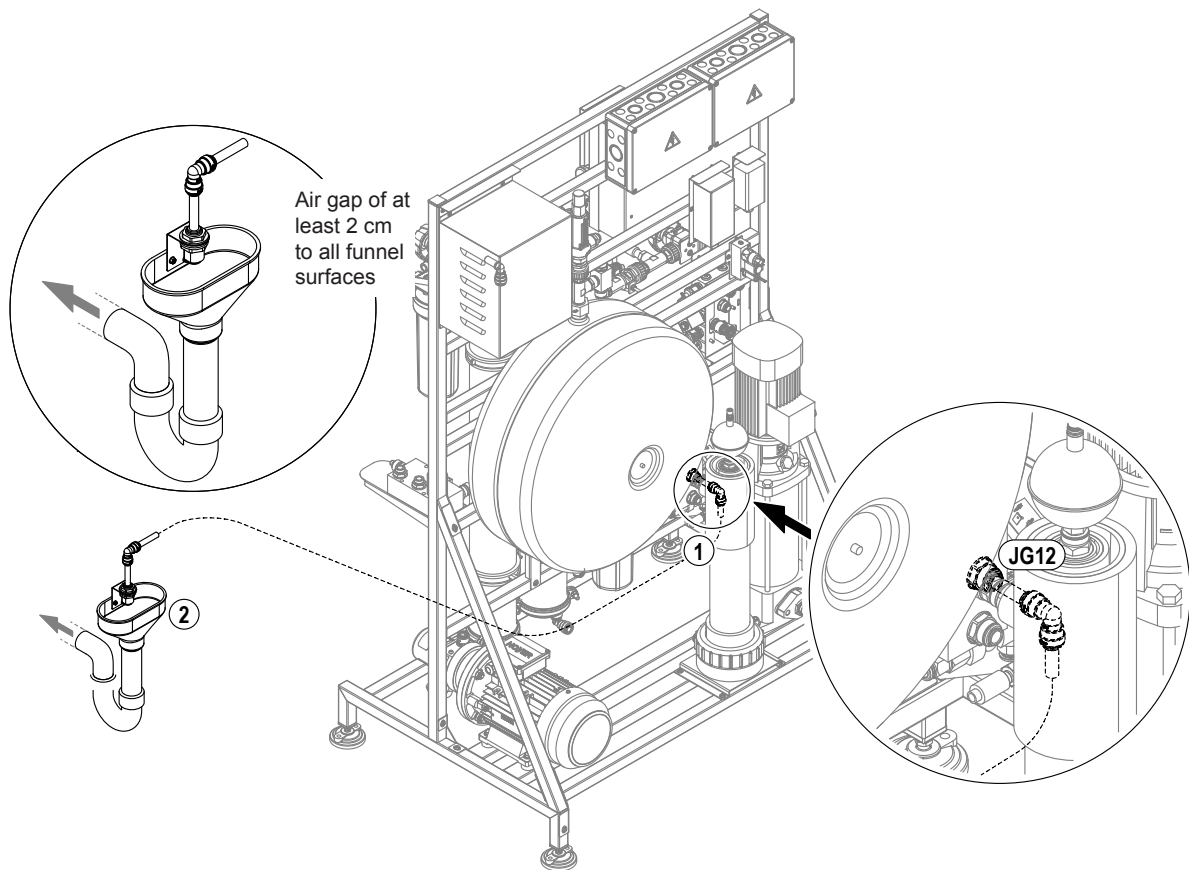

- 1 Drain hose (installation kit supplied, 5 m JG12 hose and JG12 angle connector)
- 2 Open funnel with trap, connected to the on-site waste water line (by client)

*Fig. 14: Connecting the drain line to the Condair Vita Power (image shows Condair Vita Power RO-DI-CO-UV-HP 500 l/hr, tank side)*

## 5.6.6 Connecting the high pressure lines to the Condair Vita Power

**Note:** Only for Condair Vita Power RO-DI-CO-UV-HP, RO-UV-HP and UV-HP

Connect the supplied high-pressure fittings for the ring line connection or string line connection to the high-pressure connections "In" and "Out" of the Condair Vita Power as shown in [Fig. 15](#). Then connect the high-pressure hose (string line) or the high-pressure hoses (ring line) to the corresponding fittings.

**Important:** The instructions for hose routing and hose fastening in [Section 5.6.1](#) must be strictly observed and complied with.

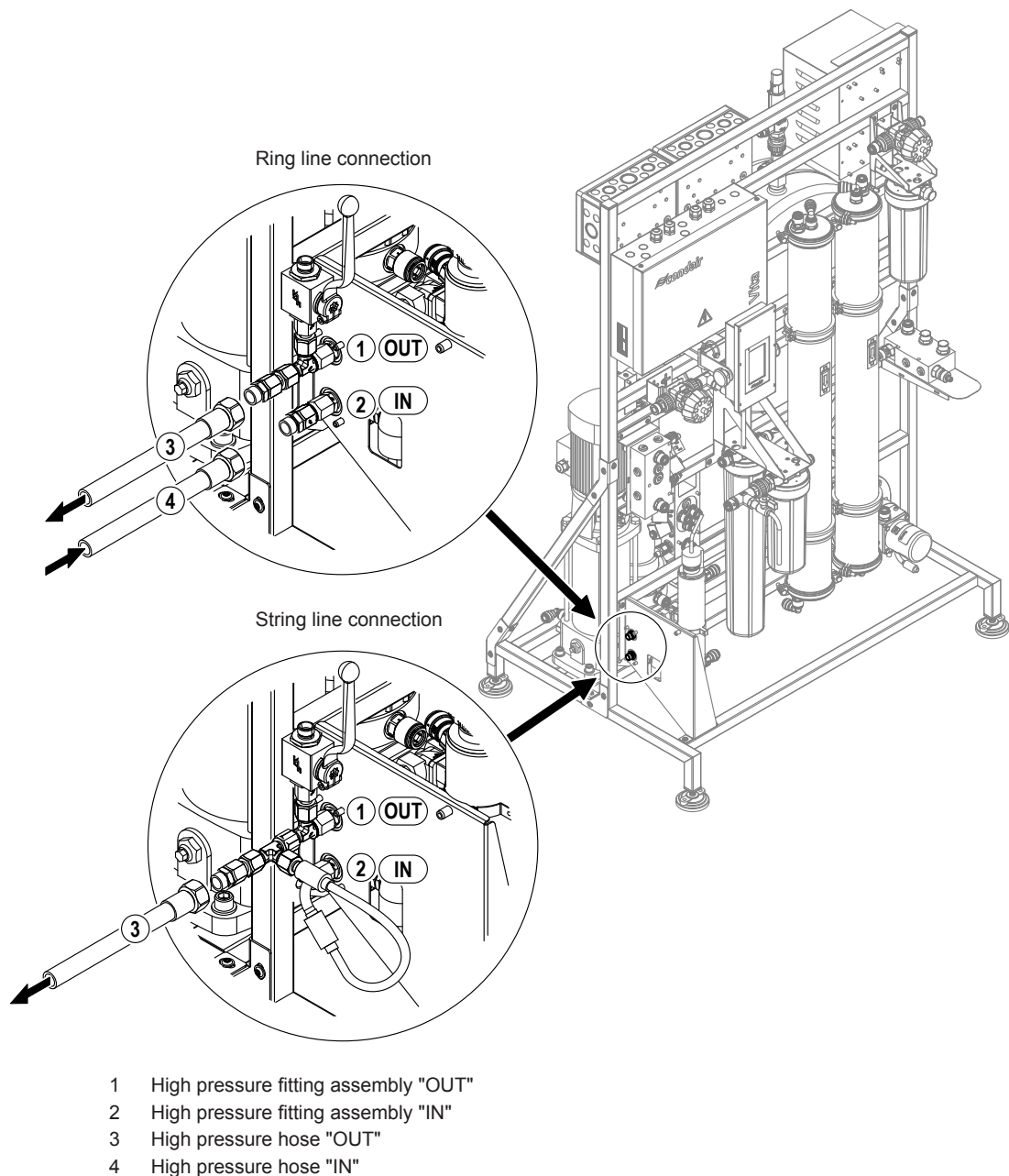

*Fig. 15: Connecting the high pressure lines to the Condair Vita Power (image shows Condair Vita Power RO-DI-CO-UV-HP 500 l/hr)*

## 5.7 Connecting the CO<sub>2</sub> compressed gas cylinder

Note: Only for Condair Vita Power RO-DI-CO-UV-HP



Ensure that the CO<sub>2</sub> compressed gas cylinder is secured against tilting using suitable means (Recommendation: Attach the CO<sub>2</sub> compressed gas cylinder to the frame of the Condair Vita Power or to the wall using a chain).

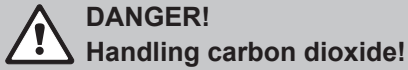

In the event of a fault in the carbon dioxide-carrying connections, the breathing air in the room can be displaced by escaping carbon dioxide (CO<sub>2</sub>). There is a risk of suffocation!

**Prevention:** Before connecting the CO<sub>2</sub> compressed gas cylinder ensure that the room is adequately ventilated. After connecting the CO<sub>2</sub> compressed gas cylinder, ensure that there are no leaks. If any are found, repair them immediately. The local safety regulations for handling compressed gas containers, especially gas containers filled with carbon dioxide (CO<sub>2</sub>), must be observed and adhered to.

For safety reasons, we strongly recommend installing a CO<sub>2</sub> sensor in the room, which will trigger an alarm in the event of a CO<sub>2</sub> leak.

The parts supplied for the CO<sub>2</sub> compressed gas cylinder must be assembled on site as shown in [Fig. 16](#) and connected to the CO<sub>2</sub> compressed gas cylinder.

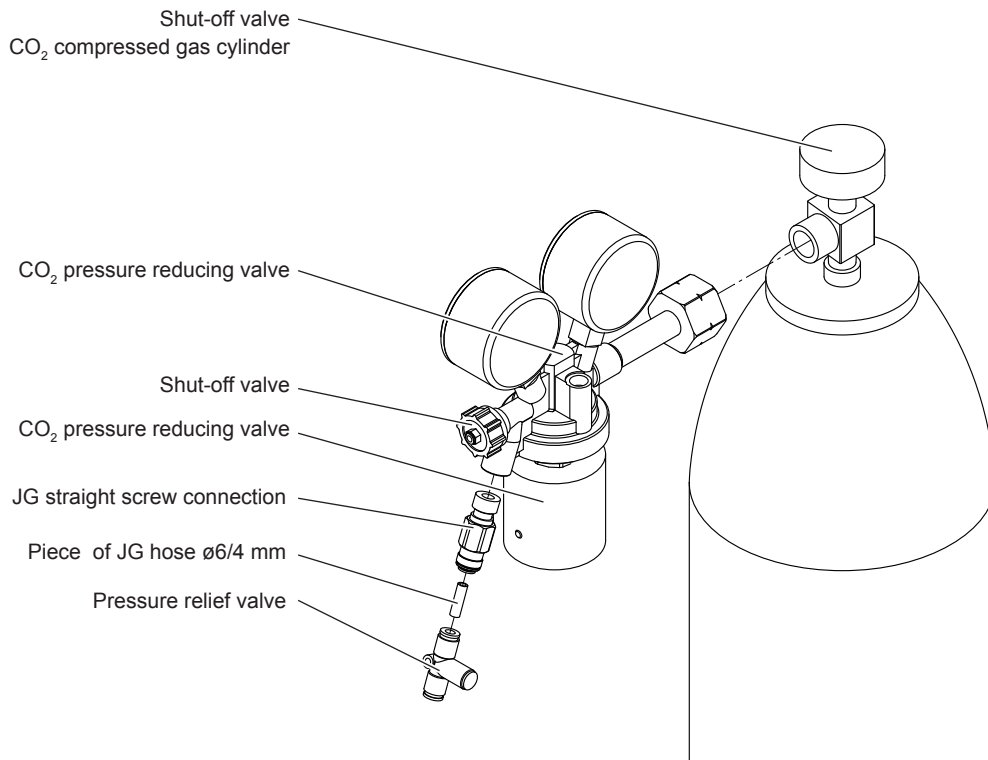

Fig. 16: Connection CO<sub>2</sub> pressure reducing valve

1. Make sure that the shut-off valve on the CO<sub>2</sub> compressed gas cylinder is closed.
2. Connect the CO<sub>2</sub> pressure reducing valve to the CO<sub>2</sub> compressed gas cylinder and tighten the union nut.

3. Make sure the shut-off valve on the CO<sub>2</sub> pressure reducing valve is closed.
4. Screw the JG straight screw connection into the connection of the CO<sub>2</sub> pressure reducing valve and tighten it.
5. Connect the pressure relief valve to the JG straight connector using a piece of JG hose  $\varnothing 6/4$  mm (length: approx. 50 mm).

The CO<sub>2</sub> compressed gas cylinder must be connected to the corresponding connection on the Condair Vita Power as shown in [Fig. 17](#) using the JG hose  $\varnothing 6/4$  mm provided.

**Important:** The instructions for hose routing, hose fastening and cutting of the JG hoses in [Section 5.6.1](#) must be strictly observed and complied with.

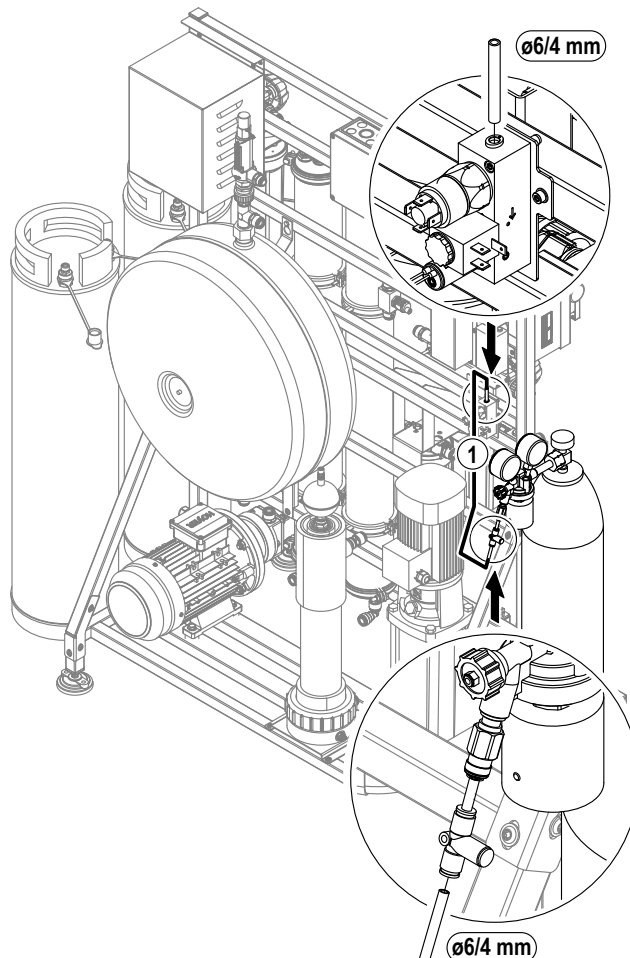

1 JG hose  $\varnothing 6/4$  mm / L= 2000 mm (supplied)

*Fig. 17: Connecting the CO<sub>2</sub> compressed gas cylinder (image shows Condair Vita Power RO-DI-CO-UV-HP 500 l/hr)*

## 5.8 Electrical installation

### 5.8.1 Notes on electrical installation



**DANGER!**  
Risk of electric shock!

**The Condair Vita Power is mains powered. Live parts may be exposed when components of the system are opened. Touching live parts may cause severe injury or danger to life.**

**Prevention:** The system (System Master) must not be connected to the power supply until all mounting and installation work has been completed and checked for correct workmanship. It must also be ensured that all covers (System Master, External control unit, connection boxes, etc.) are correctly attached and secured.

**Furthermore, ensure that the electrical isolator in the power supply to the System Master is turned off and secured in Off position against accidental activation until initial commissioning.**



**CAUTION!**

The electronic components inside the System Master are sensitive to electrostatic discharge. Before carrying out installations work inside System Master, appropriate measures must be taken to protect the electronic components against damage caused by electrostatic discharge (ESD protection).

- All work concerning the electrical installation must be carried out only by a Condair service technician or **designated specialist personnel authorized by the operator (e.g. electrician with appropriate training)** authorised by the owner. It is the owner's responsibility to verify proper qualification of the personnel.
- The electrical installation must be carried out according to the wiring diagrams (see [Section 5.8.2](#) and [Section 5.8.3](#)), the notes on electric installation as well as the applicable local regulations. All information given in the wiring diagram must be followed and observed.
- All connection cables must be routed into the interior of the System Master and the electrical isolator via appropriate cable glands.
- Ensure cables are secured in such a way that the insulation is not damaged by sharp edges and so that they do not create a trip hazard.
- Observe and maintain maximum cable length and required cross section per wire according to local regulations.
- The mains supply voltage must match the respective voltage stated on the rating plate.



## 5.8.3 Electrical installation work

### 5.8.3.1 Electrical installation of additional components

The following additional components (cables) must be connected to the System Master according to the electrical diagram (see [Fig. 18 on page 37](#)):

- The power supply cable (see [Section 5.8.3.2](#))
- The CAN bus cable of the zone control for the nebulizers (see [Section 5.8.3.3](#))
- The External control unit connection cable (see separate installation instructions of the External control unit)
- The signal cable of the regeneration contact and the salt level sensor of the optional water softener (see separate installation instructions of the water softener board)
- The signal cable of the optional external floor leak sensor (see separate installation instructions of the external floor leak sensor)

### 5.8.3.2 Connecting the 400 VAC power supply

Note: The four-pole connection cable (L1, L2, L3 and N), the second protective earth (PE) cable and the external electrical isolator must be provided by the customer and must comply with local electrical regulations.

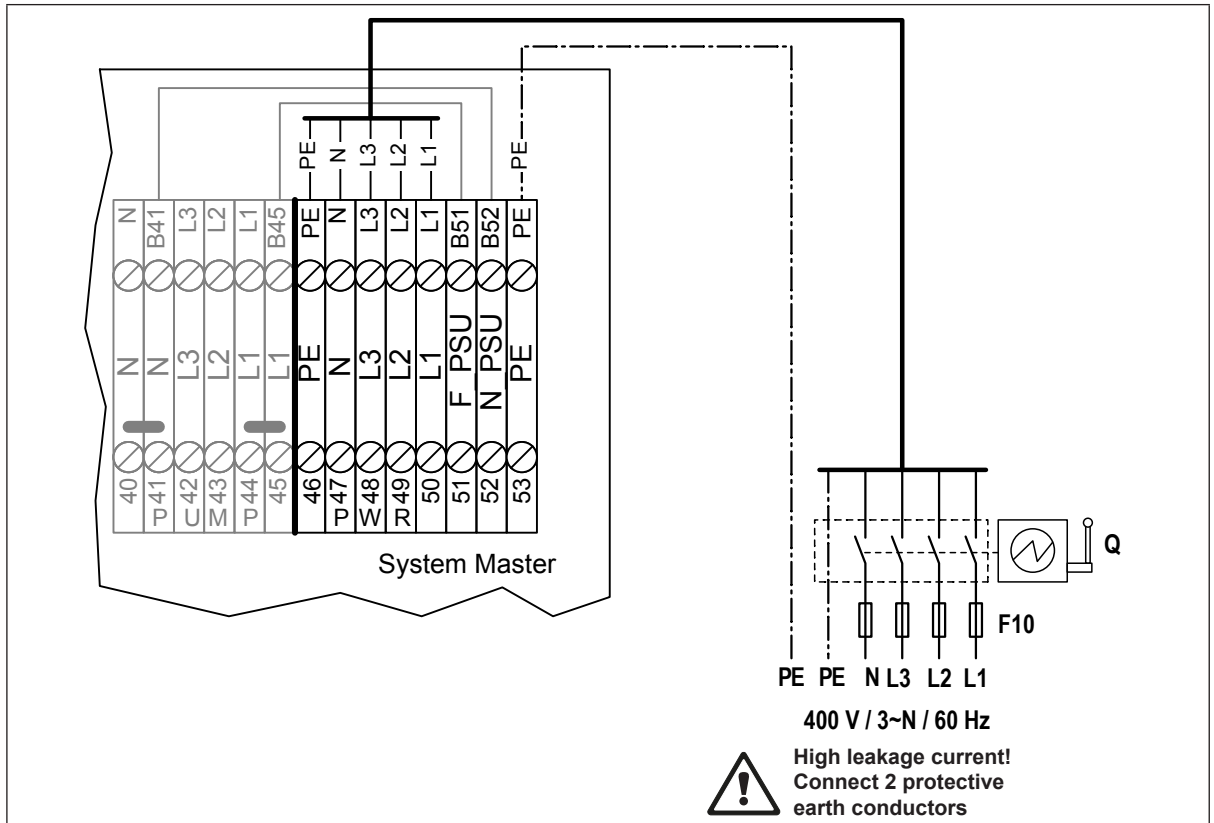

The **power supply** (L1, L2, L3, N and PE) is connected to the corresponding terminals in the System Master according to the wiring diagram.

The installation of the **fuse "F10" (16 A slow acting)**, the **electrical isolator "Q"** (all-pole disconnecting device with a minimum contact opening of 3 mm, supplied by other) and an GFCI switch with 30 mA tripping current (provided by the customer, see also note at the bottom) in the mains supply line is mandatory.

The electrical isolator must be installed in the immediate vicinity of the First Rack (max. 1 m distance) and easily accessible at a height between 0.6 m and 1.9 m (recommendation: 1.7 m).

**CAUTION!** Make sure that the voltage value listed on the rating plate corresponds to the local mains voltage. If this is not the case, do not connect the power supply to the System Master.

**DANGER!** When using a frequency converter there must be **TWO protective earth conductors (PE) for optimum safety. The second protective earth wire must be connected directly to the nearest potential equalization.** The wire cross section of both earth conductors must comply with the local regulations.

**Note:** When connecting the System Master to a power network with a GFCI switch, the GFCI switch used must be designed for operation with frequency converters and their filters. If there are problems with the GFCI switch when operating the System Master, please contact your Condair representative.

**Note:** The cross-section of the power supply cable must comply with applicable local regulations (max. cable cross-section: 4 mm<sup>2</sup>).

### 5.8.3.3 Connecting the CAN bus cable of the area control

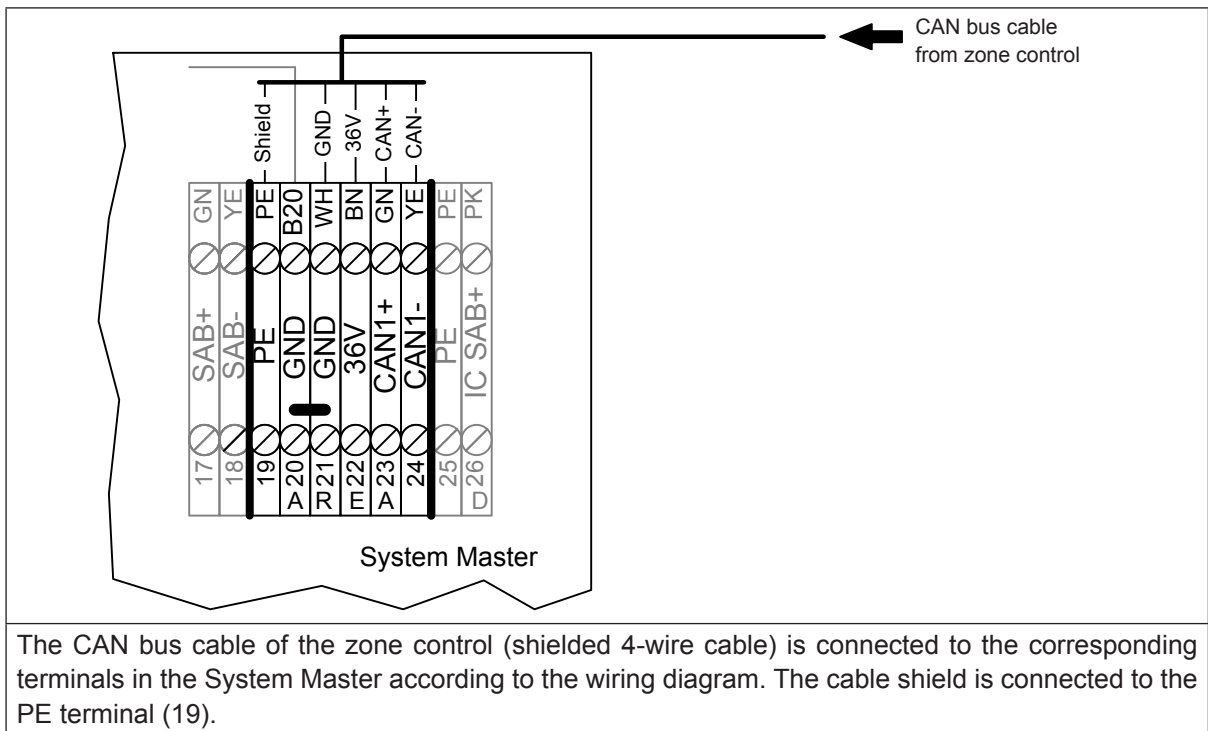

## 6 Technical data

	<b>Condair Vita Power</b>			
	<b>100</b>	<b>300</b>	<b>500</b>	
Max. production	100 l/hr	300 l/hr	500 l/hr	
Adm. supply pressure	2.5 - 4 bar			
Operating pressure	RO-DI-CO-UV-HP / RO-UV-HP / UV-HP 50 - 70 bar			
	RO 1 - 4 bar			
Dimensions (H x W x D)	RO-DI-CO-UV-HP			
	1620 x 950 x 750 mm	1620 x 1100 x 750 mm	1620 x 1100 x 750 mm	
	RO-UV-HP			
	1620 x 750 x 750 mm	1620 x 950 x 750 mm	1620 x 950 x 750 mm	
	RO			
	1620 x 750 x 750 mm	1620 x 950 x 750 mm	1620 x 950 x 750 mm	
	UV-HP 1300 x 550 x 750 mm			
Operating voltage	400 V / 3~ / 50 Hz for CE oder 208 V / 3~ / 60 Hz for UL			
Electrical power	RO-DI-CO-UV-HP / RO-UV-HP			
	2.3 kVA / 3.3 A (400V)	3.5 kVA / 5.1 A (400V)	4.0 kVA / 5.8 A (400V)	
	2.3 kVA / 6.4 A (208V)	3.5 kVA / 9.7 A (208V)	4.0 kVA / 11.1 A (208V)	
	RO			
	1.0 kVA / 1.4 A (400V)	1.4 kVA / 2.0 A (400V)	1.9 kVA / 2.7 A (400V)	
	1.0 kVA / 2.8 A (208V)	1.4 kVA / 3.9 A (208V)	1.9 kVA / 5.3 A (208V)	
	UV-HP			
	1.7 kVA / 2.5 A (400V)	2.5 kVA / 3.6 A (400V)	2.5 kVA / 3.6 A (400V)	
	1.7 kVA / 4.7 A (208V)	2.5 kVA / 6.9 A (208V)	2.5 kVA / 6.9 A (208V)	
Sound pressure level	RO-DI-CO-UV-HP / RO-UV-HP / UV-HP 74 dB (A)			
	RO 58 dB (A)			
Weight (guiding values)	RO-DI-CO-UV-HP			
	Net weight	215 kg	280 kg	280 kg
	Operating weight	224 kg	295 kg	295 kg
	RO-UV-HP			
	Net weight	145 kg	210 kg	210 kg
	Operating weight	152 kg	222 kg	222 kg
	RO			
	Net weight	105 kg	160 kg	160 kg
	Operating weight	110 kg	170 kg	170 kg
	UV-HP			
	Net weight	85 kg	90 kg	90 kg
	Operating weight	87 kg	93 kg	93 kg

# 7 Appendix

## 7.1 Hydraulic diagrams

### 7.1.1 Hydraulic diagram Condair Vita Power RO-DI-CO-UV-HP

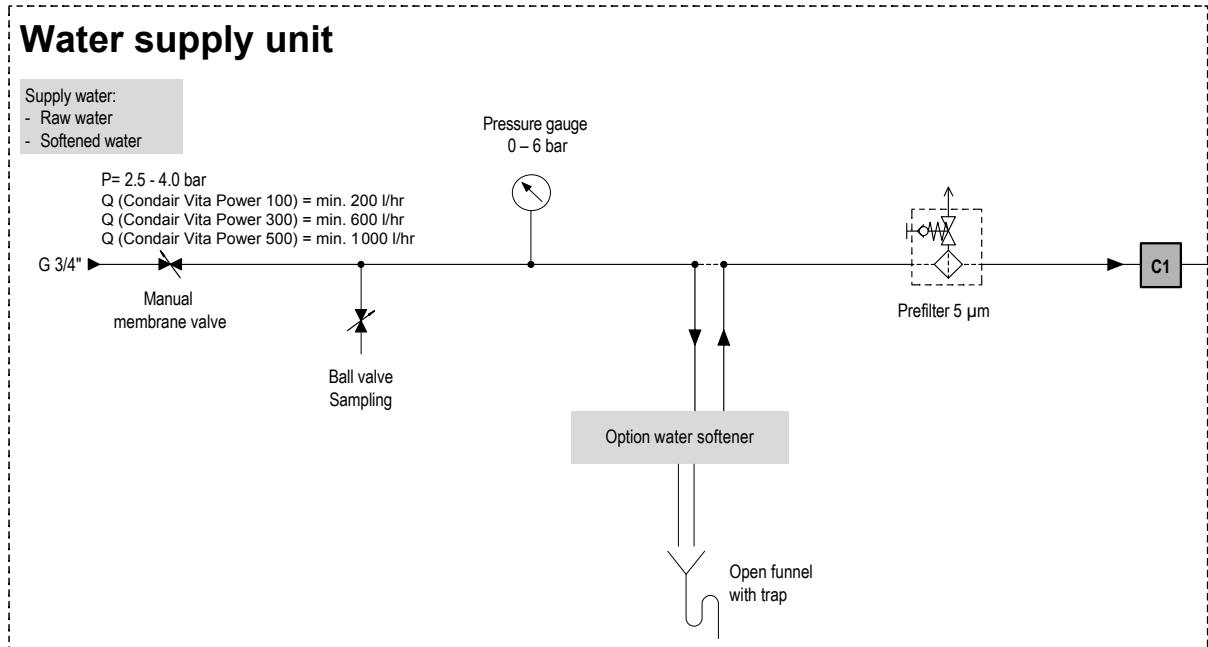

Fig. 19: Hydraulic diagram water supply

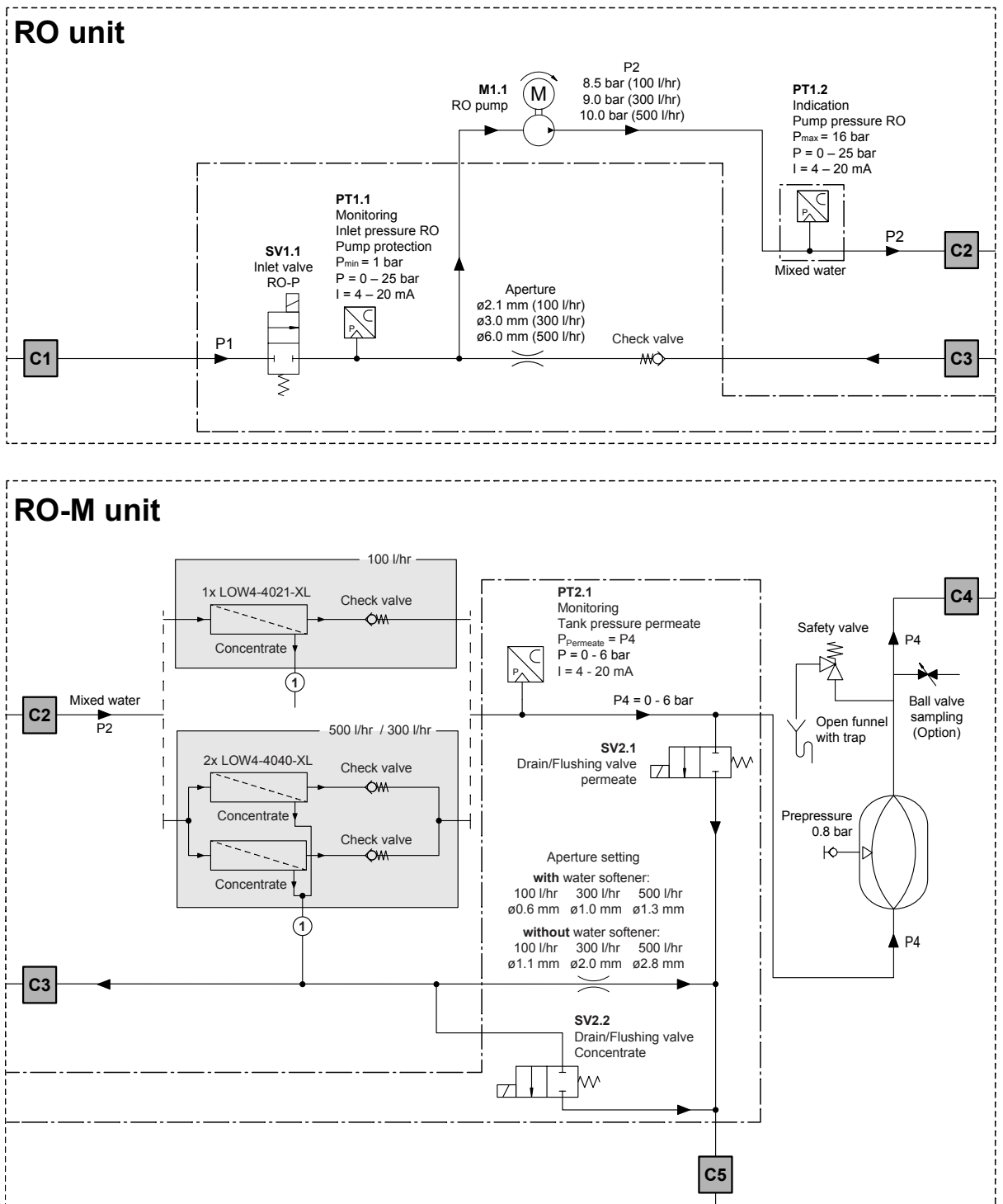

Fig. 20: Hydraulic diagram RO / RO-M unit

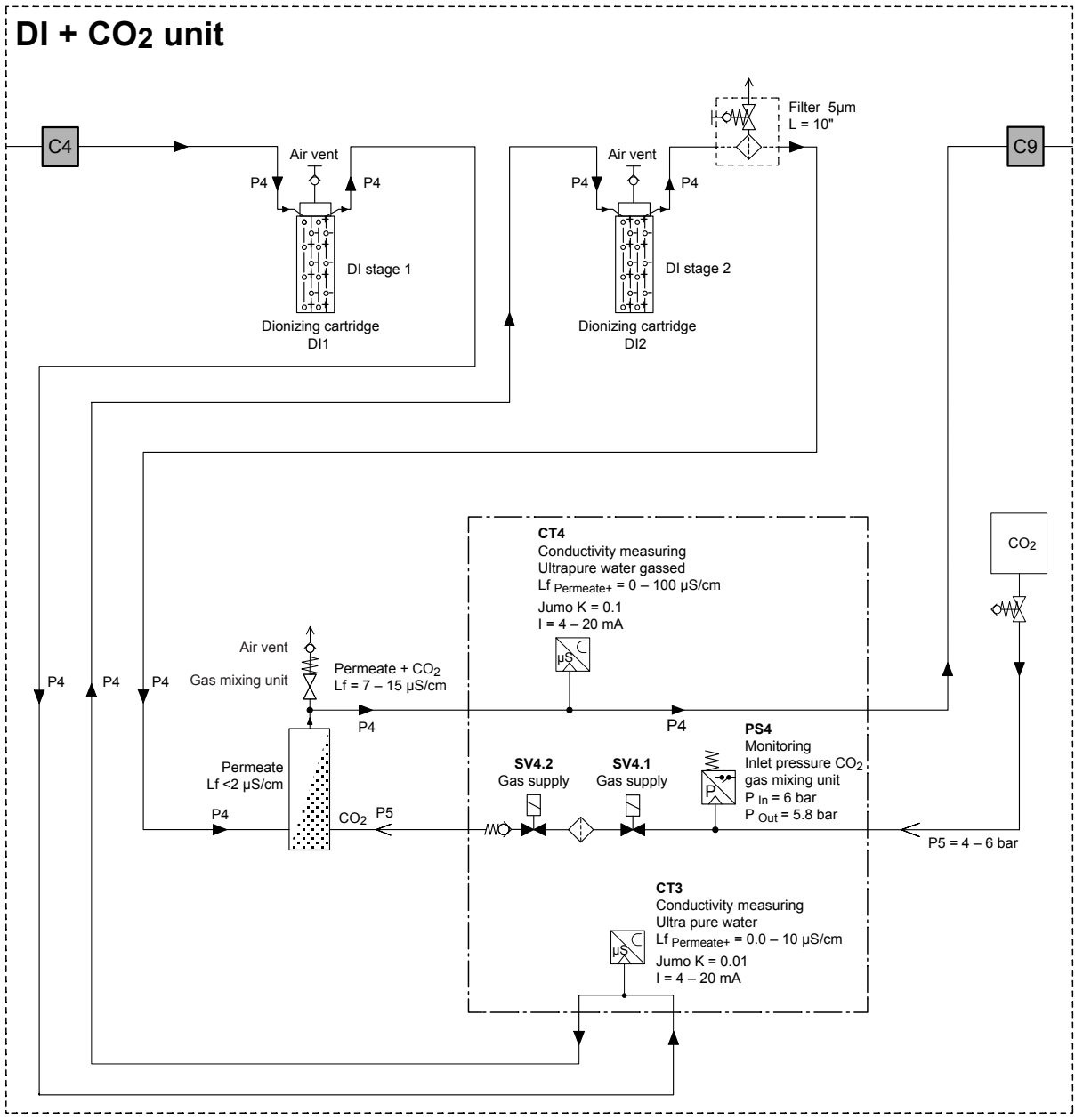

Fig. 21: Hydraulic diagram DI-CO<sub>2</sub> unit

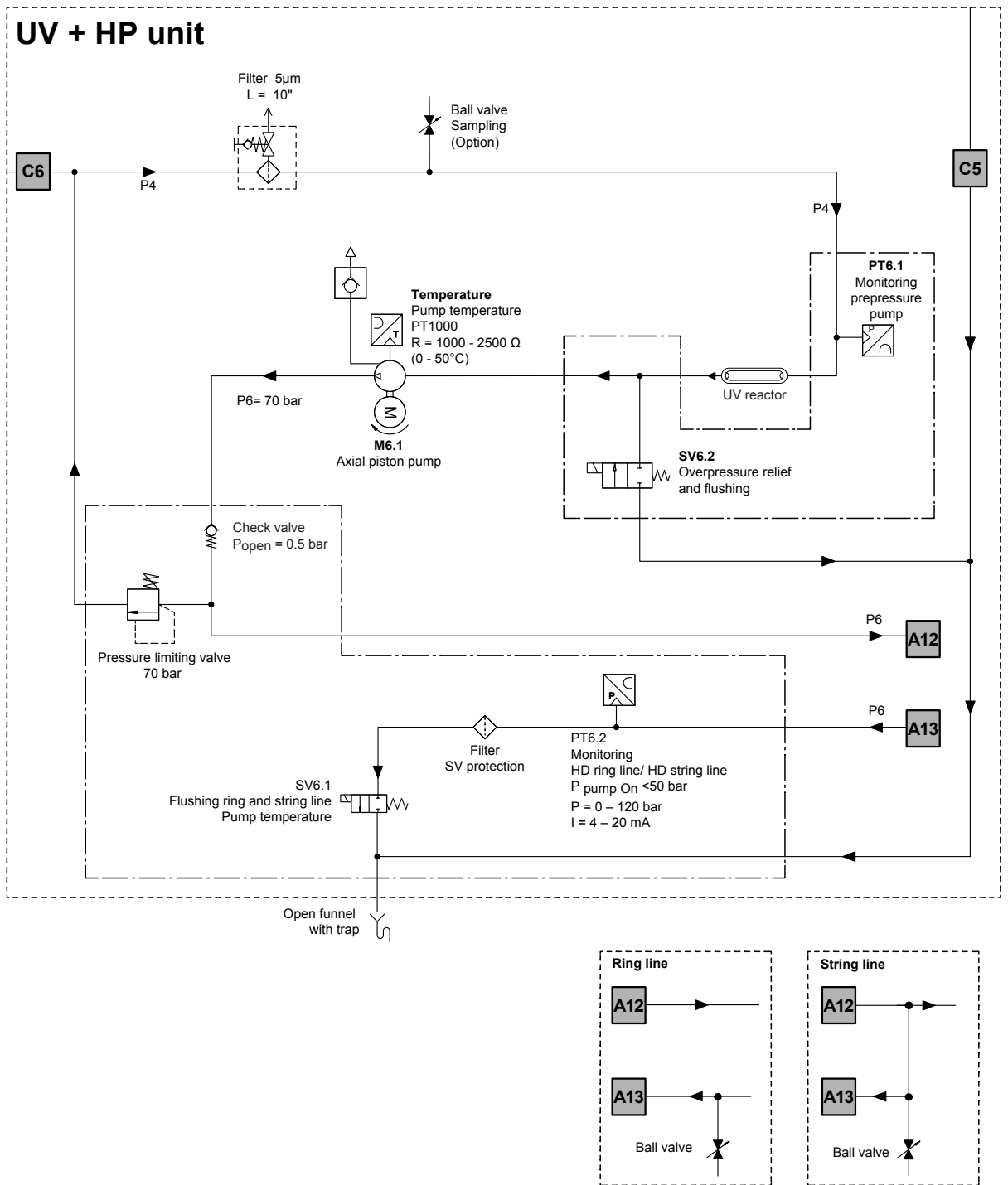

Fig. 22: Hydraulic diagram UV-HP unit

## 7.1.2 Hydraulic diagram Condair Vita Power RO-UV-HP

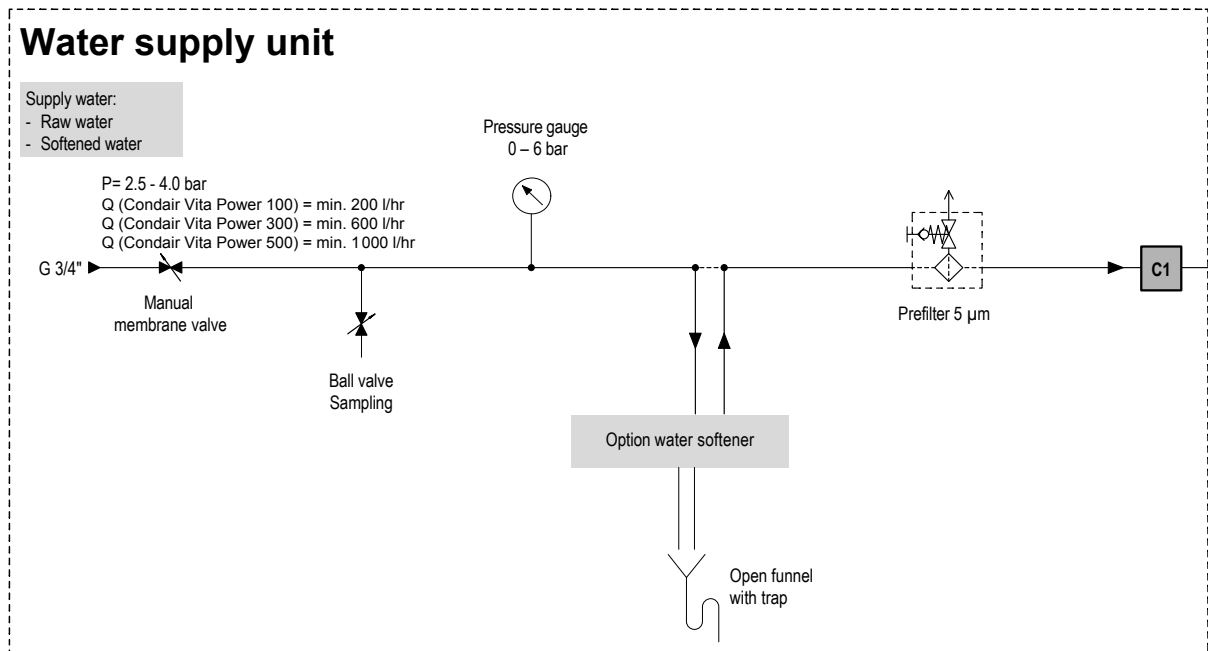

Fig. 23: Hydraulic diagram water supply

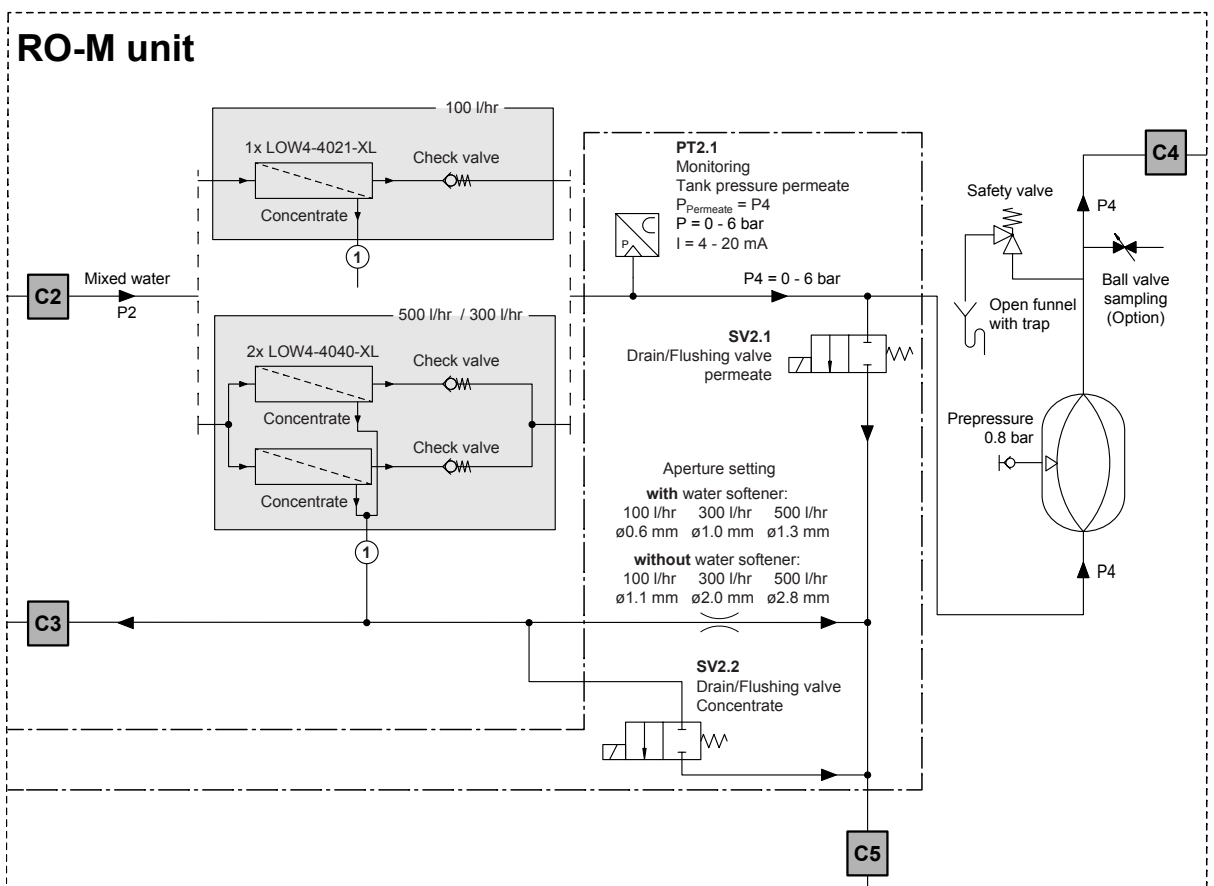
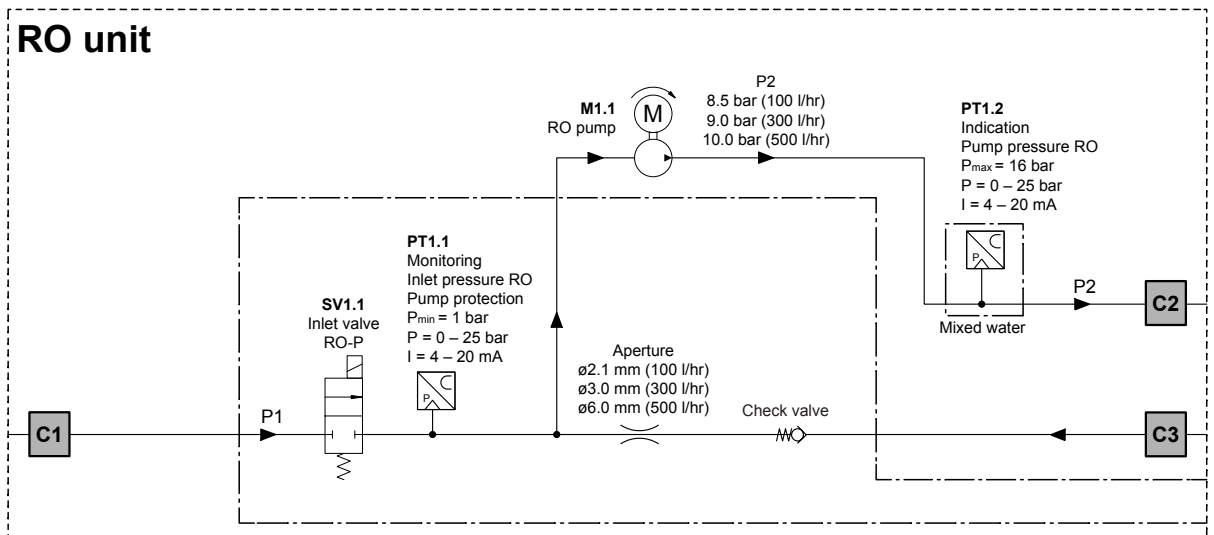

Fig. 24: Hydraulic diagram RO-P / RO-M unit

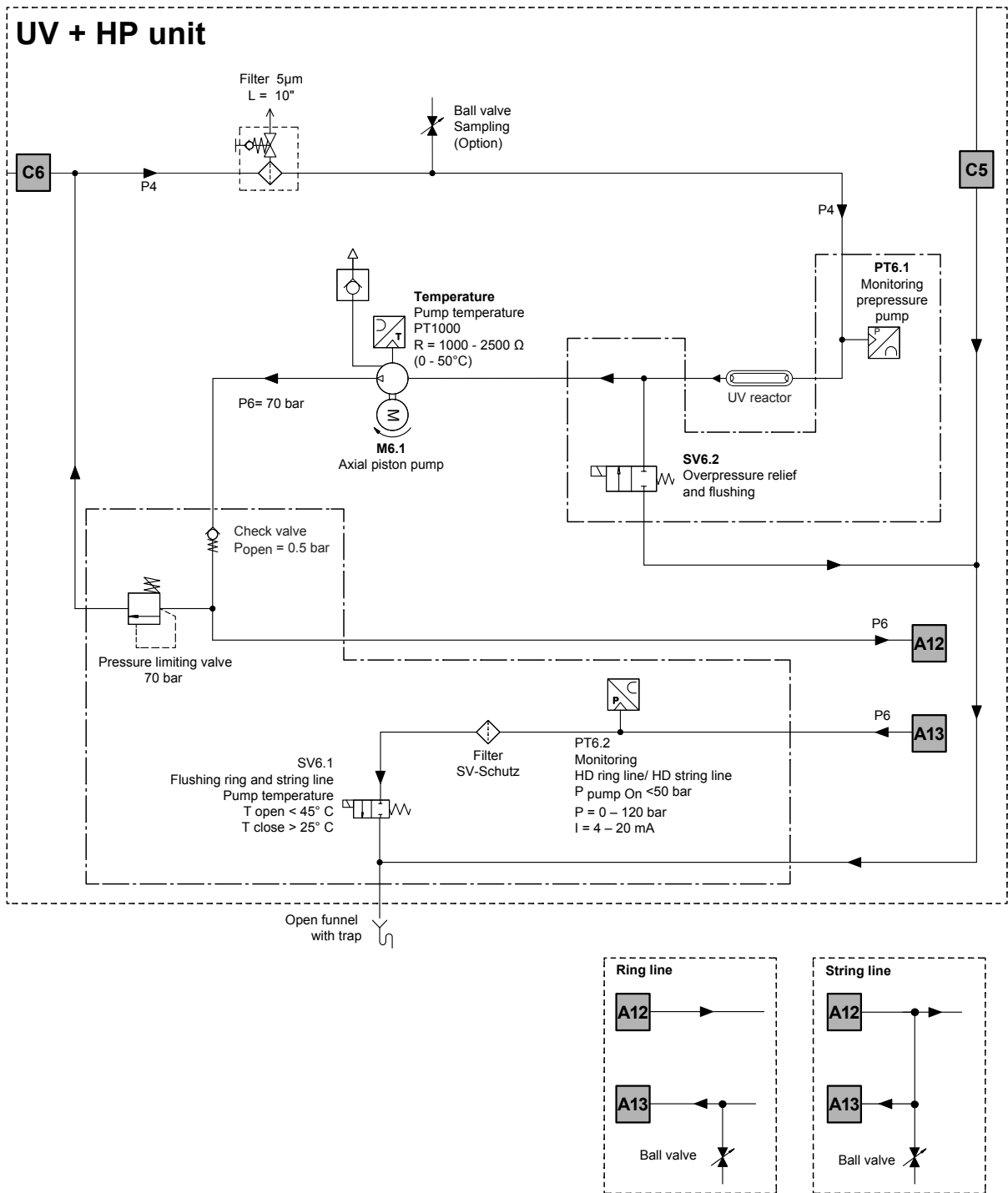

Fig. 25: Hydraulic diagram UV-HP unit

### 7.1.3 Hydraulic diagram Condair Vita Power UV-HP

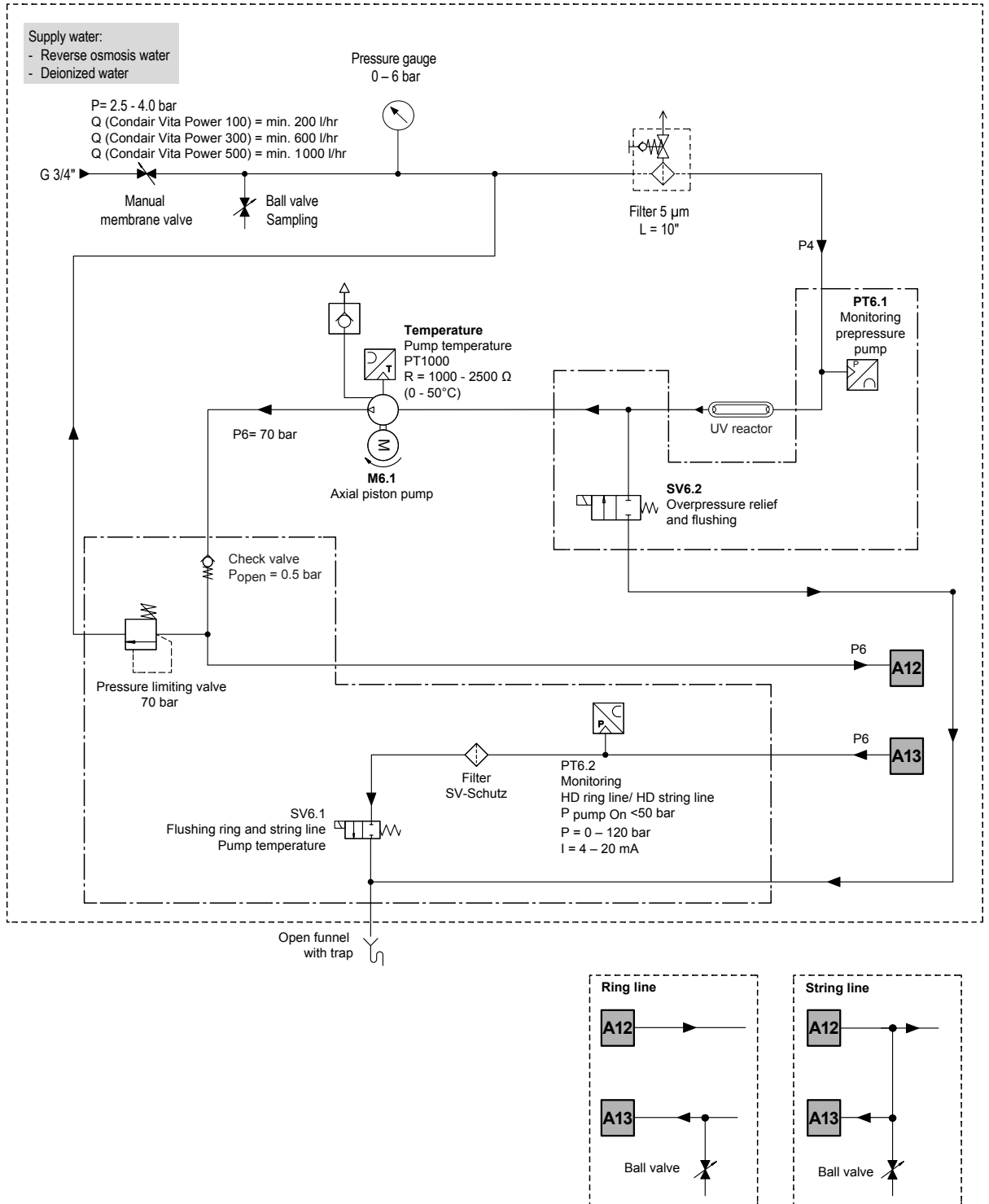

Fig. 26: Hydraulic diagram Condair Vita Power UV-HP

## 7.1.4 Hydraulic diagram Condair Vita Power RO

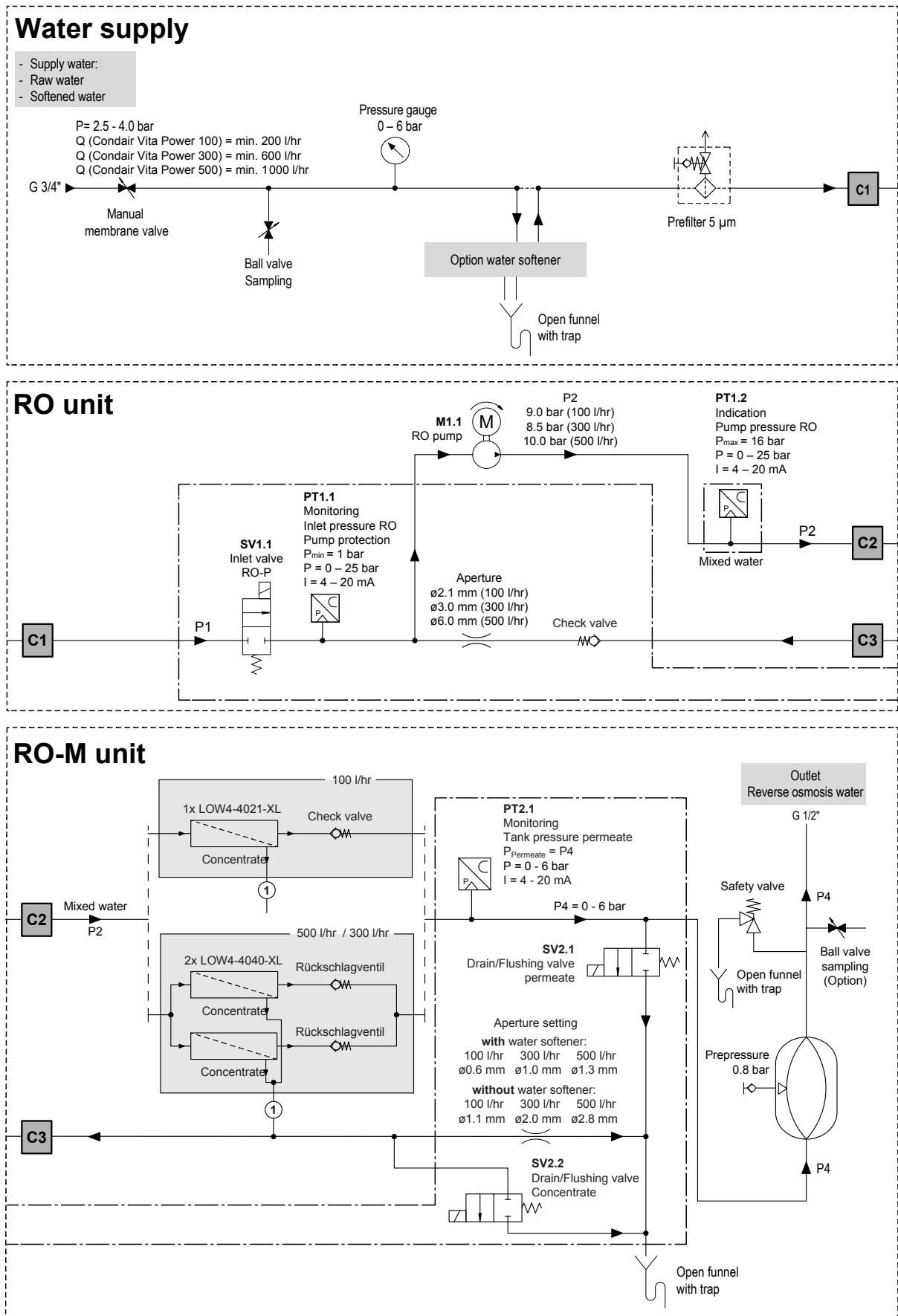

Fig. 27: Hydraulic diagram Condair Vita Power RO



CONSULTING, SALES AND SERVICE:



CH94/0002.00

Condair Group AG  
Gwattstrasse 17, 8808 Pfäffikon SZ, Switzerland  
Phone +41 55 416 61 11, Fax +41 55 588 00 07  
info@condair.com, www.condairgroup.com

The Condair logo features a stylized graphic of three wavy lines to the left of the word 'condair' in a bold, lowercase, sans-serif font.